

ZT-1
Load Module
User's Manual
For Pre-calibrated Load Cells
or other Load Cell use.

Revision: A

**THIS PAGE
INTENTIONALLY
LEFT BLANK**

Table of Contents

Limited Warranty	5
Features Overview	6
Specifications	8
Installation	10
Mounting the ZT-1	10
DC Power Connection.....	11
Shunt Resistor Selection.....	12
Strain Gage Load Cell / Sensor Connection	13
20mA-out Sensor Connection	17
10V-out Sensor Connection	18
Analog Voltage Output.....	19
Analog Current Output	20
Triggering – Internal Threshold.....	21
Triggering – External Probe	23
Calibration	25
Operation.....	30
Appendix.....	35
A) Sensor Installation (Doc# 11080)	35
B) Calibration Sheets (2) (Form# 1224)	35

Table of Figures

Figure 1: Mounting Dimensions	10
Figure 2: DC Power Wiring	11
Figure 3: Built-In 1M Ohm Shunt Resistor Wiring	Error! Bookmark not defined.
Figure 4: External Shunt Resistor Installation	12
Figure 5: Strain Gage Sensor Input	14
Figure 6: Strain Gage Sensor Cable Stripping.....	15
Figure 7: Strain Gage Sensor Wiring	16
Figure 8: 20mA-out Sensor Input	18
Figure 9: 10V-out Sensor Input.....	Error! Bookmark not defined.
Figure 10: Analog Voltage Output Wiring.....	19
Figure 11: Analog Current Output Wiring.....	20
Figure 12: Internal Threshold Wiring.....	22
Figure 13: Probe Input Wiring	23
Figure 14: Probe Timing Diagram	24
Figure 15: Calibration Gain Voltage Measurement	28
Figure 16: Calibration Card Sample.....	29

Limited Warranty

This unit is warranted by the manufacturer, Edrive Actuators, Inc., to be free of defects in workmanship and materials for one year from date of manufacturer's shipment. This warranty is limited to repairing or replacing products which manufacturer's investigation shows were defective at the time of shipment by the manufacturer.

All products subject to this warranty must be returned for examination, repair or replacement

F.O.B. to: EDRIVE Actuators, Inc.
 385 Stamm Road
 Newington, CT 06111
 Office: 860-953-0588

The express warranty set forth herein is in lieu of all other warranties, expressed or implied, including without limitation any warranties of merchant-ability or fitness for a particular purpose. All such warranties are hereby disclaimed and excluded by the manufacturer.

Repair or replacement of defective products as provided above is the sole and exclusive remedy provided thereunder. The manufacturer shall not be liable for any further loss, damages, or expenses, including incidental or consequential damages, directly or indirectly arising from the sale or use of this product.

Any unauthorized repair voids this warranty.

There are no warranties that extend beyond those expressly set forth herein.

Features Overview

- Designed to work with strain gage sensors and load cells. The ZT-1 can also accept input from 4-20mA current output sensors or voltage output sensors.
- Simultaneously provides normal peak, reverse peak, and track voltage outputs. Also simultaneously provides the associated 0-20mA current outputs.
- Built-in threshold trigger simplifies installation. External probe trigger can also be used when situation required.
- LED bar-graph voltmeter for easy setup and diagnostic.
- Built-in 1 Mega Ohm calibration shunt resistor. User selected external shunt resistor can be used for load cell applications.
- x1 and x10 amplifier gain ranges to work with either strong or weak signal from the load sensor.
- Auto-Zero can be selected using dip switches to compensate for zeroing errors caused by environmental changes such as temperature, humidity, and etc.
- Electrical noise rejection filter can be enabled when situation required.
- Plug-in connectors for easy wiring and installation.
- Standard DIN Rail mount simplifies systems integration.
- Modular with common bus design allows future upgrade and expansion.

The ZT-1 tonnage load module is designed for critical force measurement applications where accuracy, extreme stability, and dependable noise rejection is essential. It is equipped with an LED bar-graph voltmeter for easy setup and diagnostic. The ZT-1 is DIN rail mountable and is designed to interface with a PLC analog card and to display output through a human machine interface (HMI).

**THIS PAGE
INTENTIONALLY
LEFT BLANK**

Specifications

Transducers	Full bridge, 120 to 1000 ohms.
Sensor Excitation	Built in +10VDC at 250mA max.
Balance Range	+/- 1mV/V of sensor imbalance
Gain Ranges	Low range = x50 to x550 adjustable High range = x500 to x5,500 adjustable
Calibration Shunt	Built-in 1 mega ohm (.1%), or external custom shunt.
Output Range - Voltage	Normal Peak and Reverse Peak = 0 to 10VDC Track output = -10 to +10VDC
Output Range - Current	Normal Peak and Reverse Peak = 0 to 20mA Track output = -20 to +20mA
Circuit Inaccuracy	+/- .1% of full scale max.
Circuit Non-linearity	+/- .02% of full scale max.
Auto Zero	Time constant = 10 seconds. DIP switch selectable.
Frequency Response	DC to 5,000 Hz
Speed Limit	2000 SPM max. when triggered by External Probe 500 SPM max. when triggered by Internal Threshold
Operating Temperature	-4 to 158 degree F, or -20 to 70 degree C
Display	LED bar-graph voltmeter for setup and diagnostic
Trigger	Internal Threshold (.35V / .70V), or External Probe.
Probe Input	NPN/PNP proximity probes, solid state or dry contact relays. Built-in 24VDC at 80mA max. supplies power to the probe.
Input Power	24VDC at 300mA max. Automatic resettable fuse.
Dimensions	0.9" W x 4.1" H x 4.7" D
Mounting	Standard DIN Rail mount

**THIS PAGE
INTENTIONALLY
LEFT BLANK**

➤ Installation

Mounting the ZT-1

The ZT-1 is designed to clip onto standard top hat DIN rail (TH 35-7.5 or TH 35-15).

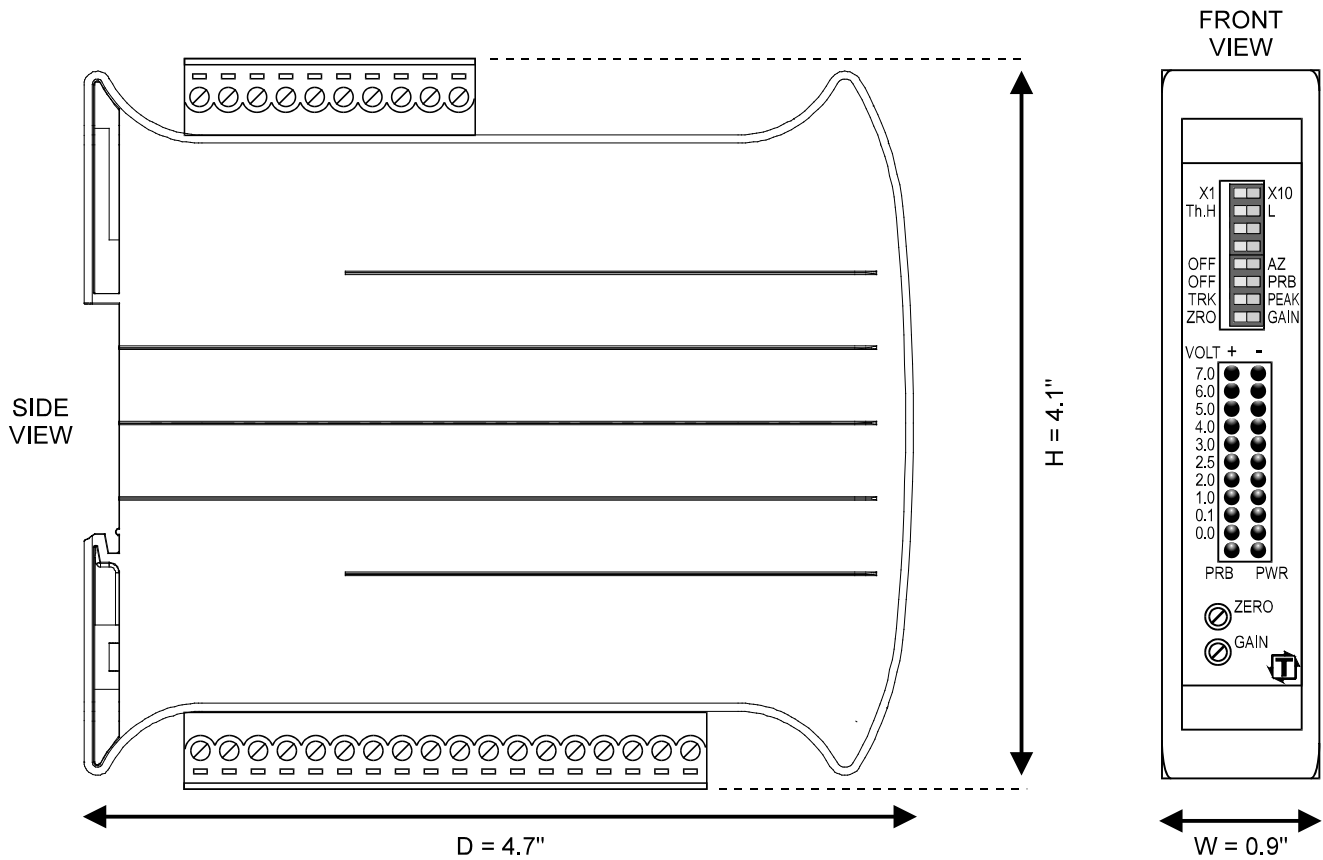

Figure 1: Mounting Dimensions

DC Power Connection

24VDC power is connected to the ZT-1 as shown in Figure 2.

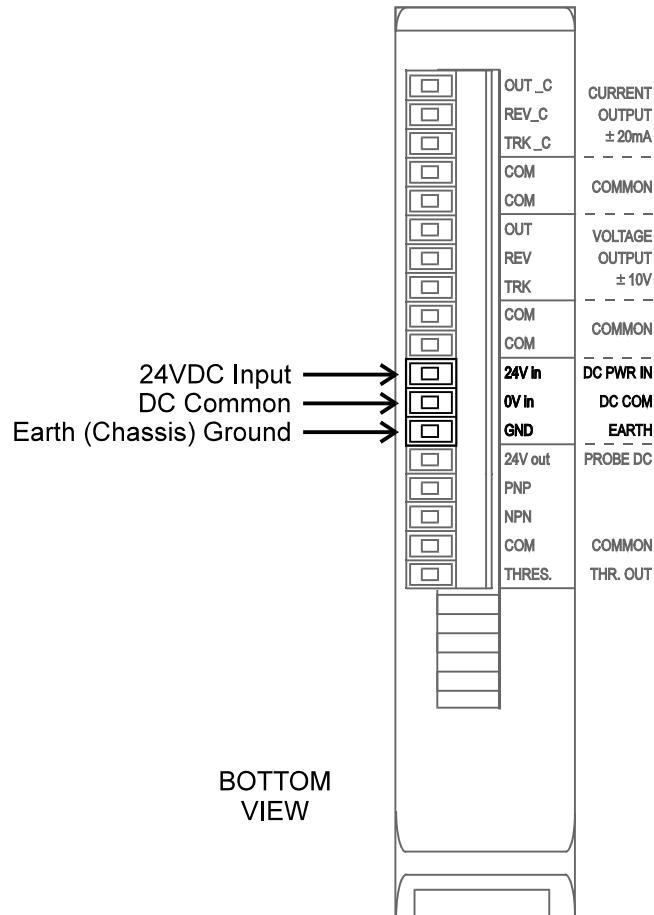

Figure 2: DC Power Wiring

Notes:

- 1) The 24VDC source can be in range from 18VDC to 32VDC.
- 2) It is important to connect an Earth Ground to the GND terminal.
- 3) Do not apply power until all the wirings in this Installation Section are done.

Shunt Resistor – Strain Gage Load Cells

Shunt resistor only works directly with the Strain Gage Wheatstone bridge type load cells and sensors.

User-specified external shunt resistor value is indicated on calibration data report..

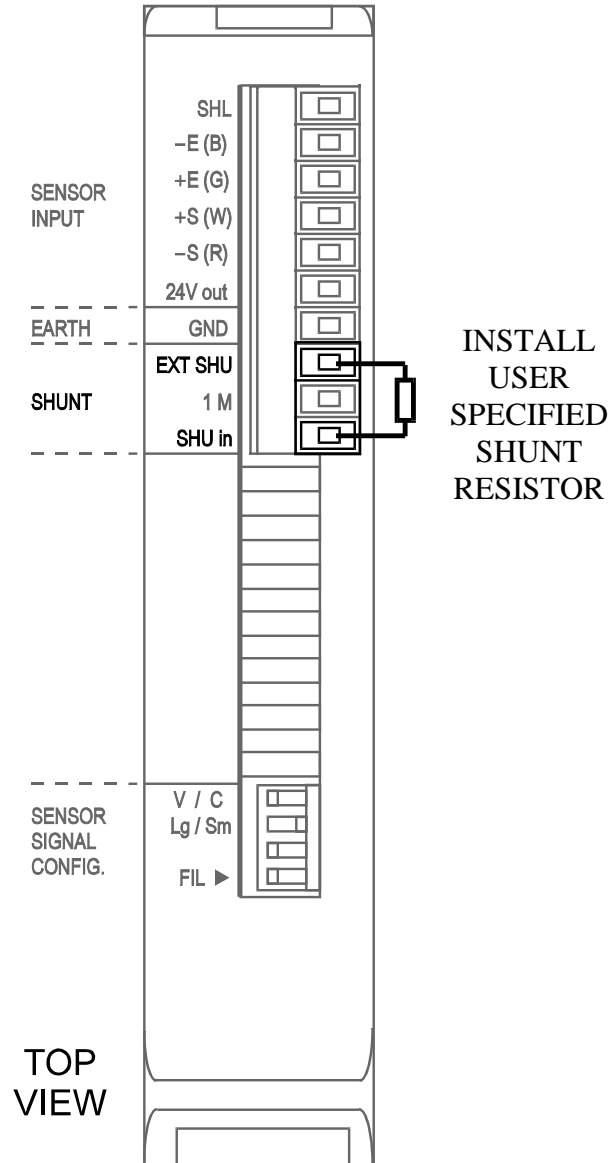

**Figure 3:
External Shunt
Resistor Installation**

Strain Gage Sensor Connection

Refer to Figure 4 for the procedures below:

Connection:

- 1) Prepare the sensor cable for termination as described in Illustration A on page 15.
- 2)** Remove the Phoenix plug from its socket on the top of the unit and wire the sensor cable as described in Illustration B on page 16.

For specific load cell wire color code, refer to Load Cell Specifications. Color Code wire designation may be different than shown in Figure 4 & 6.

- 3) The Phoenix plug can then be inserted back into its socket.

Configuration:

- 1) Set the V / C dip switch to “V” position for voltage sensor. Strain Gage sensor outputs voltage signal.
- 2) Set the Lg / Sm dip switch to “Sm” position for small signal. Strain Gage sensor outputs un-amplified signal (small signal).
- 3) Set FIL dip switch to “No filter” position. Apply this filter only when electrical noise becomes a problem at the ZT-1 analog outputs.

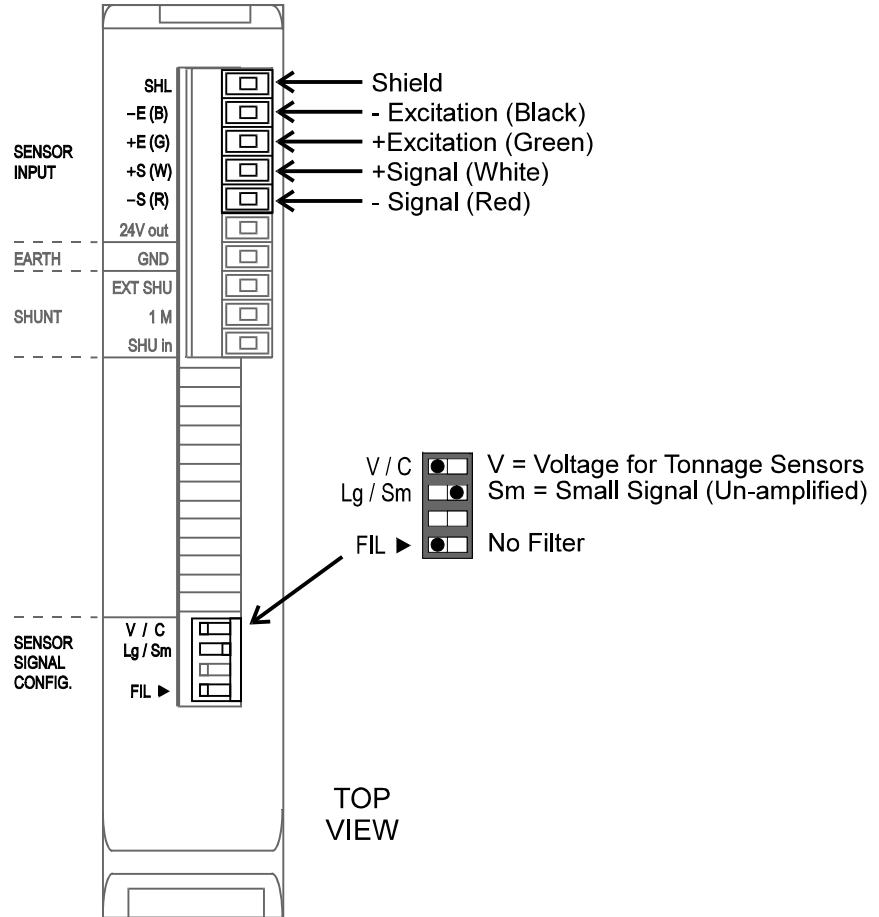

Figure 4: Strain Gage Sensor Input

Illustration A - Sensor Cable Termination

- 1) Strip the sensor cable as shown in Figure 5 below. Be sure not to nick any of the signal conductors or cut the braid shield.

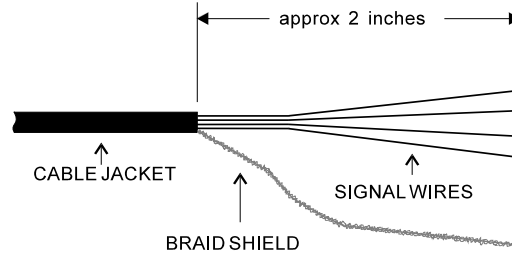

Figure 5: Strain Gage Sensor Cable Stripping

- 2) Strip approximately $\frac{1}{4}$ " of insulation from each of the four signal conductors.

Note: If your sensor cable is not double shielded with both foil and a braid, electrical noise may affect your output readings.

Illustration B - Sensors Connection

The ZT-1 accepts the signals from all strain gage load cells and sensors. Figure 6 illustrates the sensor connections.

To be more specific, refer to load cell specifications for other color configurations.

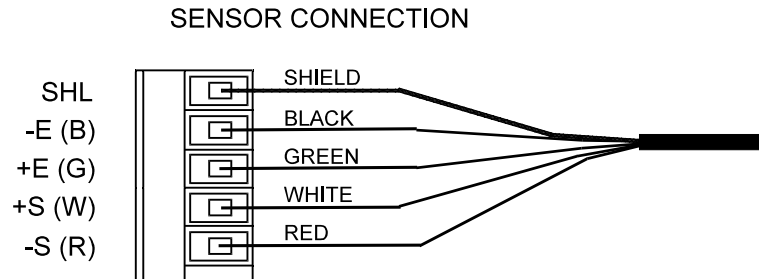

Figure 6: Typical Load Cell Wiring

20mA-out Sensor Connection

The 20mA-out Sensor applies to sensors with output up to +/-20mA including the 4-20mA output sensor. Refer to Figure 7 for the procedures below:

Connection:

- 1) Remove the Phoenix plug from its socket on the top of the unit and wire the sensor cable as shown.
- 2) The Phoenix plug can then be inserted back into its socket.

Configuration:

- 1) Set the V / C dip switch to "C" position for current output sensor. 20mA-out sensor outputs current signal.
- 2) Set the Lg / Sm dip switch to "Lg" position for large signal. 20mA-out sensor outputs amplified signal (large signal).
- 3) Set FIL dip switch to "No filter" position. Apply this filter only when electrical noise becomes a problem at the ZT-1 analog outputs.

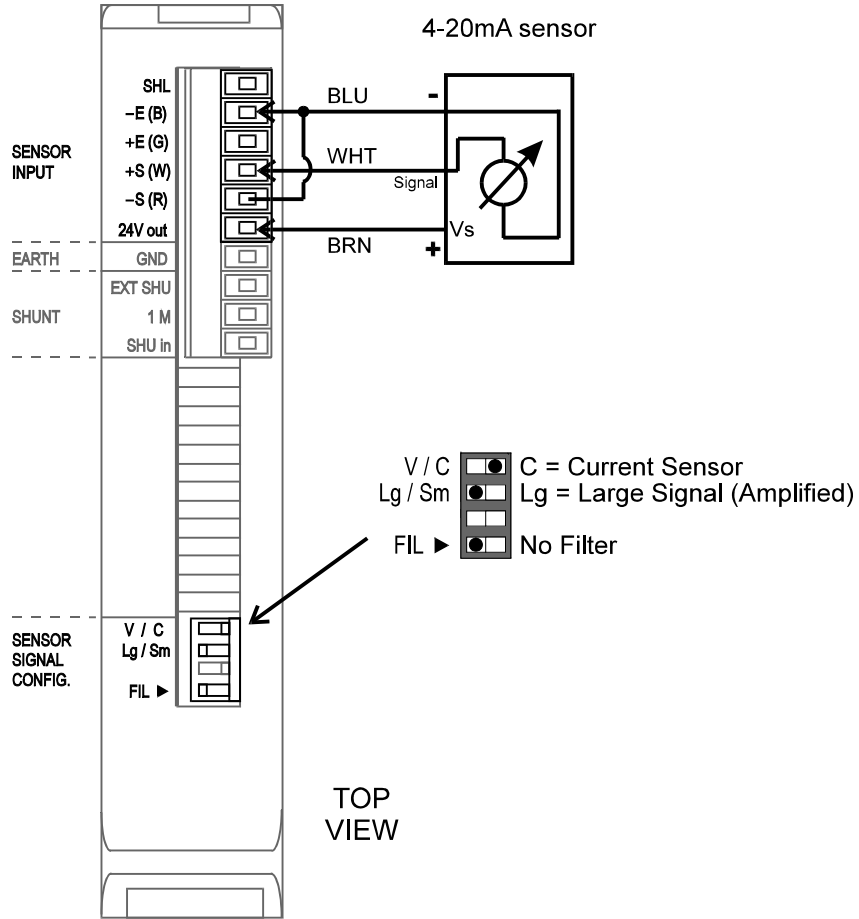

Figure 7: 20mA-out Sensor Input

Analog Voltage Output

The analog voltage output is provided on a Phoenix connector for easy access and for interfacing with other peripherals.

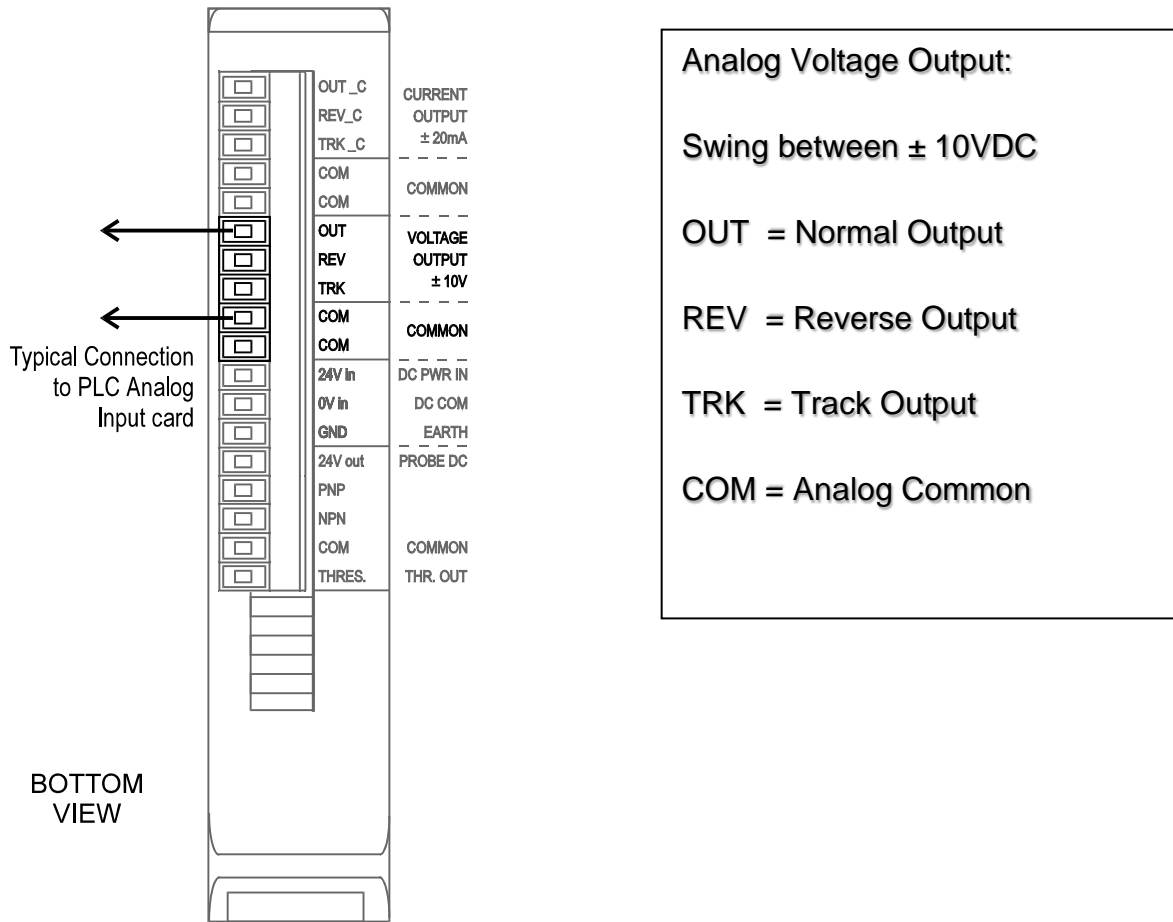

Figure 8: Analog Voltage Output Wiring

Output details:

- OUT terminal outputs either Peak tonnage or Track tonnage, depending on the TRK/PEAK switch setting on the front panel.
- REV terminal outputs the reverse peak (snap-through) tonnage when the front panel TRK/PEAK switch is set to PEAK.

- TRK terminal always outputs the track tonnage, regardless of the front panel TRK/PEAK switch.

Analog Current Output

The analog current output is provided on a Phoenix connector for easy access and for interfacing with other peripherals.

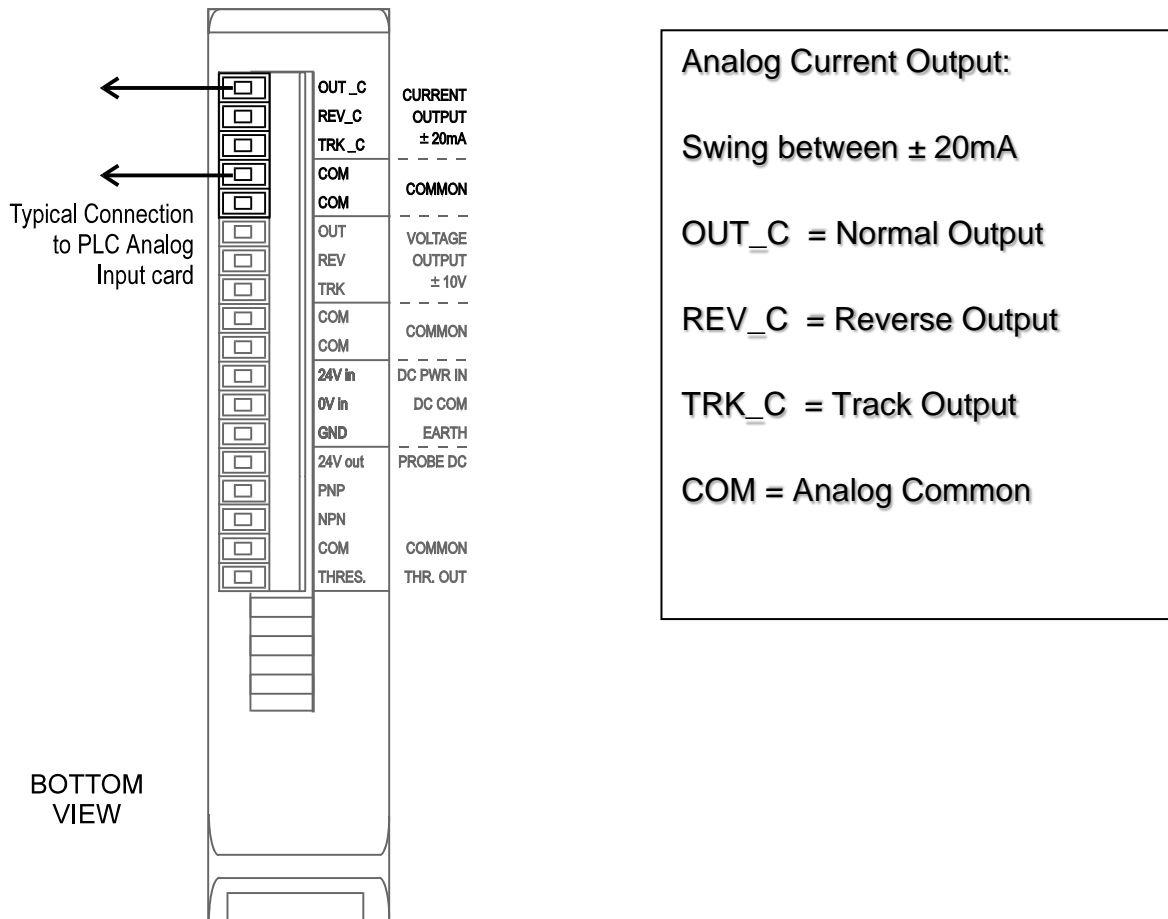

Figure 9: Analog Current Output Wiring

Output details:

- OUT_C terminal outputs either Peak tonnage or Track tonnage, depending on the

TRK/PEAK switch setting on the front panel.

- REV_C terminal outputs the reverse peak (snap-through) tonnage when the front panel TRK/PEAK switch is set to PEAK.
- TRK_C terminal always outputs the track tonnage, regardless of the front panel TRK/PEAK switch.

Triggering – Internal Threshold

The ZT-1 can be triggered by an internal threshold value. When this triggering method is used, the ZT-1 begins monitoring when the load rises above the level determined by the front panel's **Th.H / L** switch. Refer to Figure 10 below to configure the ZT-1 for threshold triggering.

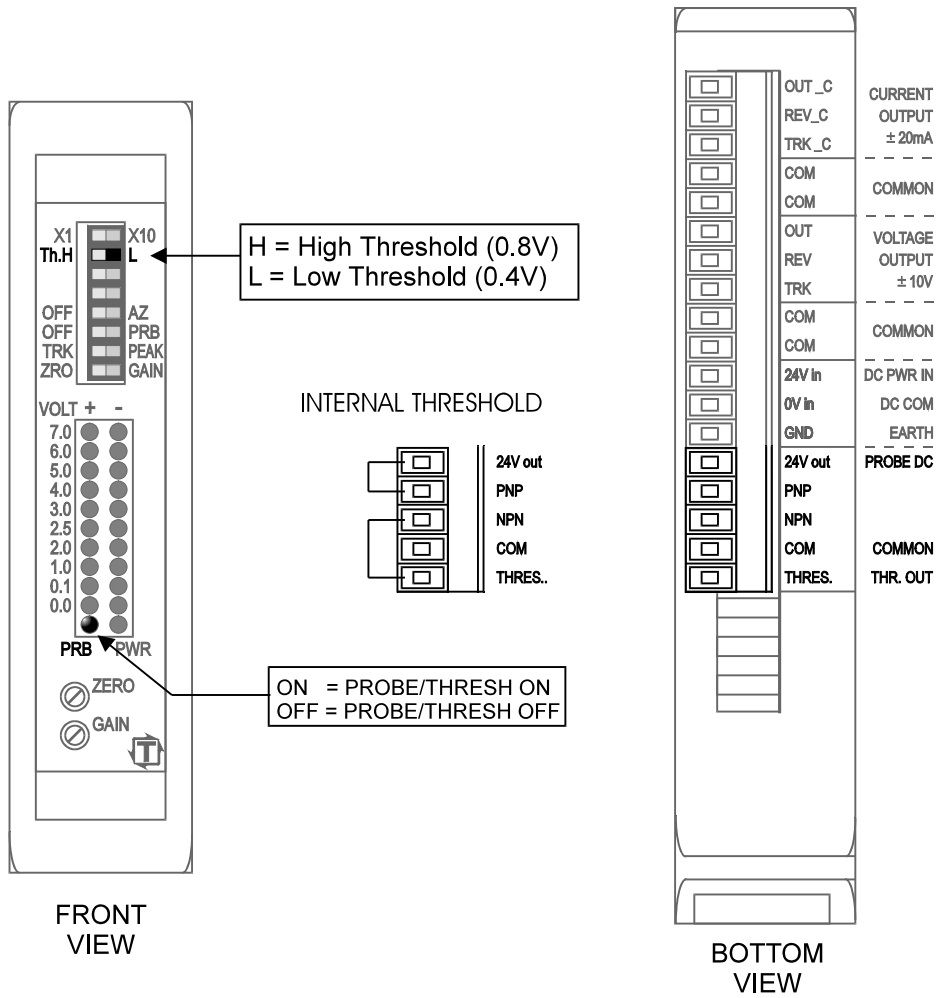

Figure 10: Internal Threshold Wiring

The probe (PRB) indicator should turn on when the load rises above the threshold value, and turn off when the load falls back below the threshold value.

Triggering – External Probe

The ZT-1 can be triggered by an external probe signal. If an external probe is used, the probe supply voltage (+24VDC) is provided by the ZT-1. The figure below illustrates the wiring for a variety of sensing devices.

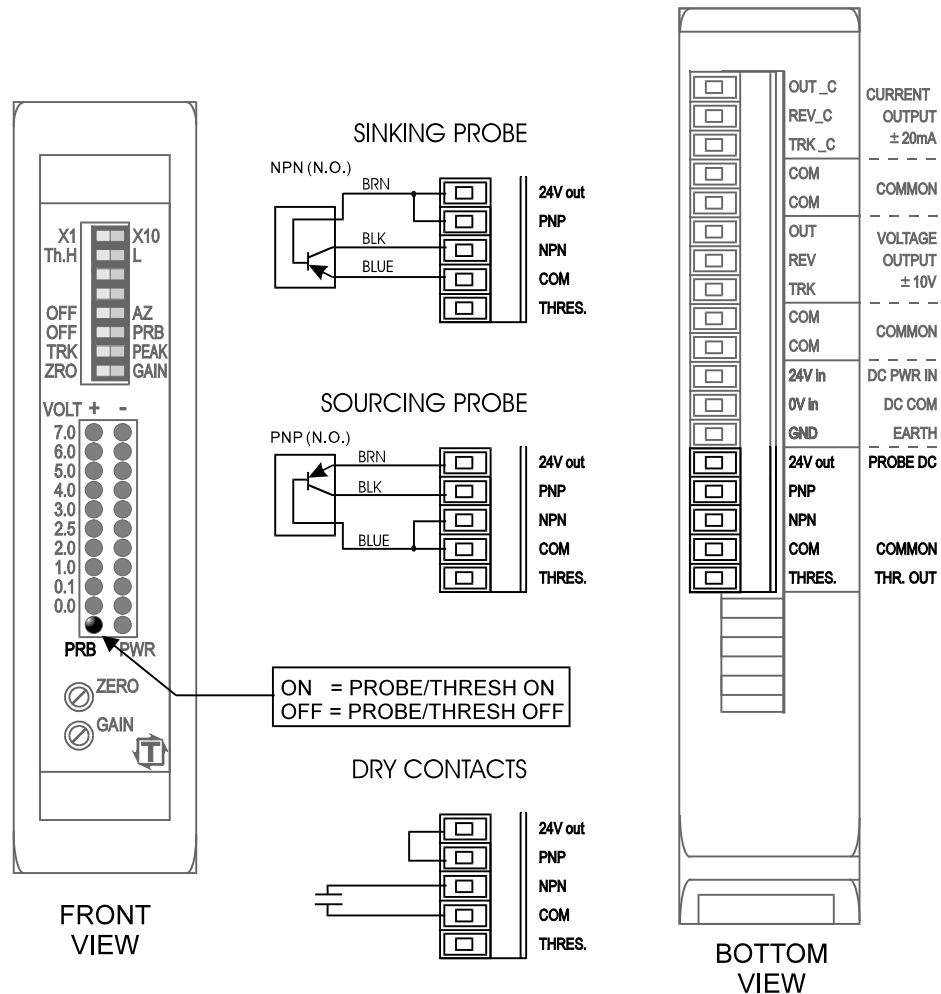

Figure 11: Probe Input Wiring

The probe (PRB) indicator should turn on when the probe turns on, and turn off when the probe turns off.

If the front panel Auto-Zero switch is enabled, the ZT-1 will remain in the auto-zeroing mode of operation until an external probe is applied.

The auto zero feature is important for accurate readings. Over time the press frame will slightly change in its structure. This may be due to temperature or press frame tension. The ZT-1 will compensate for the slight change. It will readjust the zero base line. This zero base line is the no-load value of the press. With a consistent zero value, the tonnage output readings should remain accurate.

When the probe turns on, the ZT-1 opens the window to read a load signal. In peak mode the load level rises to the highest value.

When the probe turns off, the peak level is held at its high level and the auto-zeroing function is resumed (Notice the dotted line below). The peak level is reset the next time the probe transitions from off to on.

The timing of the probe should be such that it turns on just before the machine begins generating a load (140°) and remains on until the load is removed (240°).

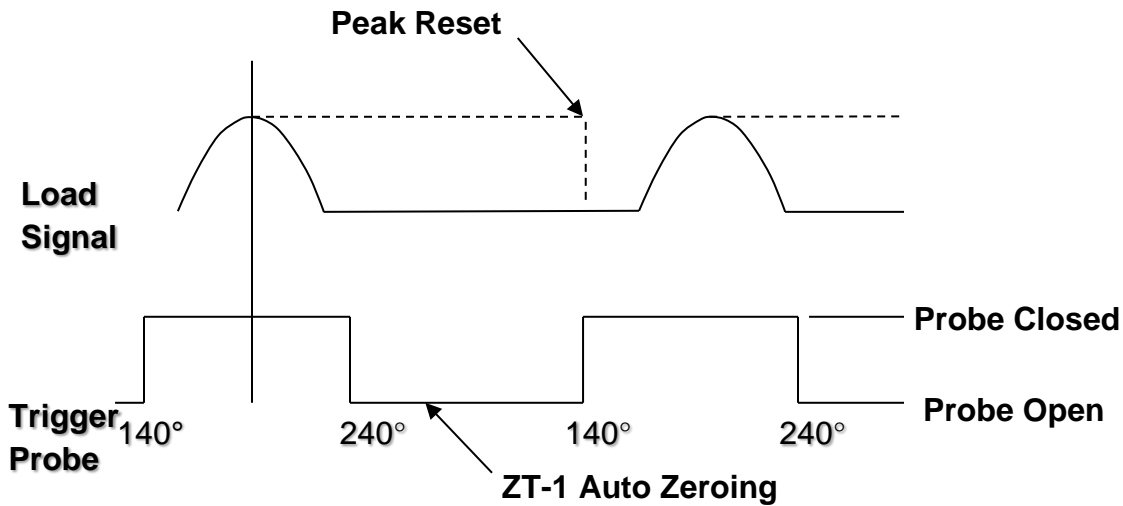

Figure 12: Probe Timing Diagram

➤ Calibration

Refer to the Calibration Data Report issued for each model and serial number load cell. Load cells and data reports are identified by model number, serial number and date of calibration.

Pre-calibrated systems. When installing, be sure to match up the specific load cell model number and serial number to the specified ZT1 serial number indicated on corresponding calibration data report.

Pre-calibrated systems should not need adjustments made to the ZT1.

In the case where the system was not pre-calibrated or needs calibration, follow procedure below.

Refer to the diagram below for control locations.

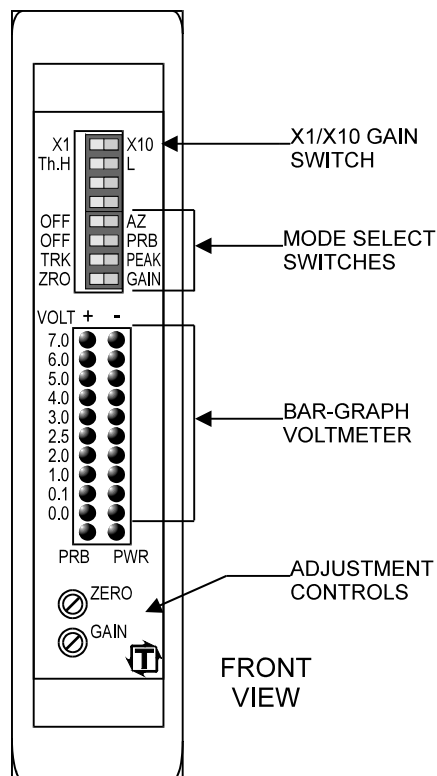

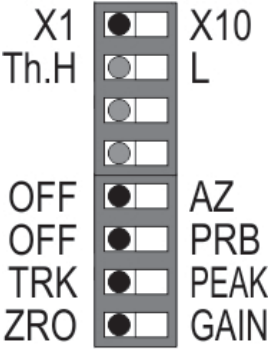

- 4) Install Shunt Resistor provided with each load cell, enclosed in calibration data report plastic cover.
- 5) Balance the load cell to zero.

- Adjust the ZERO pot until digital voltmeter shows 0.000 volts.

Note: Measure output voltage with a digital voltmeter across the OUT and COM terminals (see Figure 13).

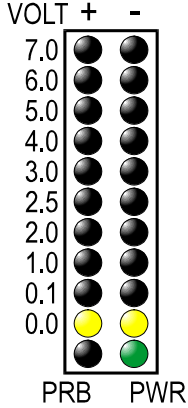

6)

- Set the mode switches to AZ OFF, PRB, PEAK, and ZERO.

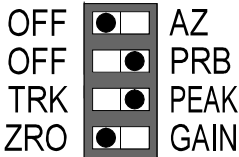

7) Adjust the gain.

- Refer to calibration data report for specific “cal. number” in VDC. If no calibration data report, apply known load.
- Adjust the GAIN pot until the digital volt meter reads same as “cal. Number” VDC. If no calibration data report, adjust gain pot to desired output voltage. eg. 7.0 VDC.
- Repeat steps 5-7 until the correct voltages are achieved.
For example, +7.0V. 10.0 VDC is the maximum, verifiable with a calibrated multimeter.

Note: Use the VOLT LED in the built-in bar-graph voltmeter as an indicator of movement to required cal. number value. This characteristic applies to all LED's in this built-in bar-graph voltmeter.

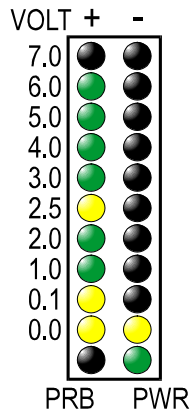

8) Record the Calibration Gain Voltage.

- Set the mode switches to AZ OFF, PRB OFF, TRK, and ZERO as shown, and verify that the sensor is at zero.

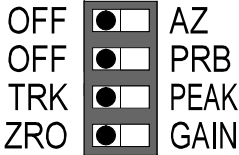

- Set the ZRO/GAIN switch to GAIN and use a digital voltmeter to measure the voltage across the OUT and COM terminals. Record this value as the Calibration Gain Voltage.

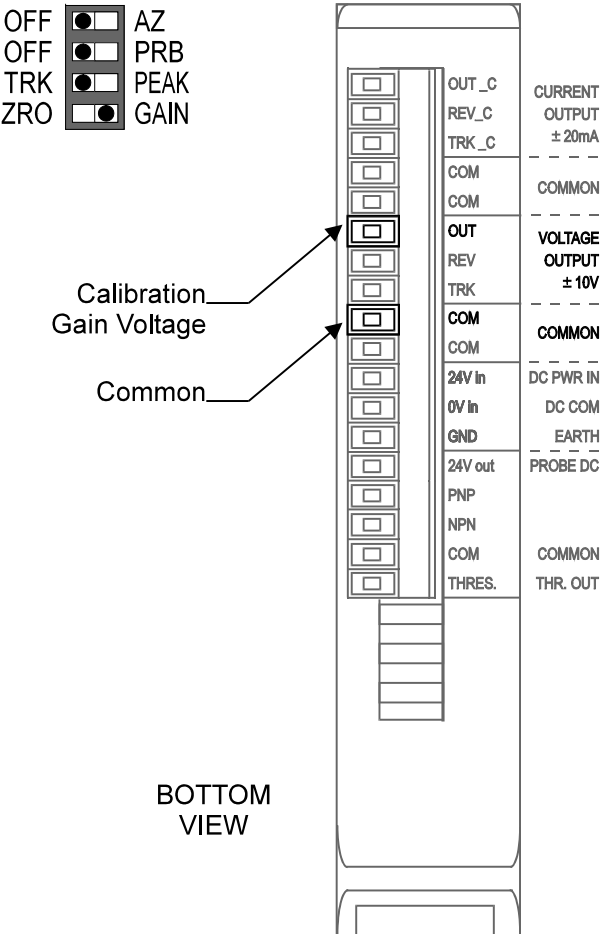

Figure 13: Calibration Gain Voltage Measurement

9) Calibration complete.

- Fill in the Calibration Card (a sample shown below) which is located in the side pocket.
- Set mode switches as shown.

OFF	<input checked="" type="checkbox"/>	AZ
OFF	<input checked="" type="checkbox"/>	PRB
TRK	<input checked="" type="checkbox"/>	PEAK
ZRO	<input checked="" type="checkbox"/>	GAIN

Model ZT-1		Serial No. <u> A1501 </u>																																
Calibrated By: <u> John Doe </u>		Date: <u> 1-1-2015 </u>																																
Mode Switch <small>(Fill In Switch Position)</small>		Sensor Config. <small>(Fill In Switch Position)</small>																																
<table border="0"> <tr> <td>X1</td> <td><input type="checkbox"/></td> <td>X10</td> </tr> <tr> <td>Th.H</td> <td><input type="checkbox"/></td> <td>L</td> </tr> <tr> <td></td> <td><input type="checkbox"/></td> <td></td> </tr> <tr> <td></td> <td><input type="checkbox"/></td> <td></td> </tr> <tr> <td>OFF</td> <td><input checked="" type="checkbox"/></td> <td>AZ</td> </tr> <tr> <td>OFF</td> <td><input checked="" type="checkbox"/></td> <td>PRB</td> </tr> <tr> <td>TRK</td> <td><input checked="" type="checkbox"/></td> <td>PEAK</td> </tr> <tr> <td>ZRO</td> <td><input checked="" type="checkbox"/></td> <td>GAIN</td> </tr> </table>	X1	<input type="checkbox"/>	X10	Th.H	<input type="checkbox"/>	L		<input type="checkbox"/>			<input type="checkbox"/>		OFF	<input checked="" type="checkbox"/>	AZ	OFF	<input checked="" type="checkbox"/>	PRB	TRK	<input checked="" type="checkbox"/>	PEAK	ZRO	<input checked="" type="checkbox"/>	GAIN	Shunt: _____ Ohm (if EXT used) Gain: <u> 3.25 </u> VDC	<table border="0"> <tr> <td>V / C</td> <td><input type="checkbox"/></td> </tr> <tr> <td>Lg / Sm</td> <td><input checked="" type="checkbox"/></td> </tr> <tr> <td></td> <td><input type="checkbox"/></td> </tr> <tr> <td>FIL ▶</td> <td><input checked="" type="checkbox"/></td> </tr> </table>	V / C	<input type="checkbox"/>	Lg / Sm	<input checked="" type="checkbox"/>		<input type="checkbox"/>	FIL ▶	<input checked="" type="checkbox"/>
X1	<input type="checkbox"/>	X10																																
Th.H	<input type="checkbox"/>	L																																
	<input type="checkbox"/>																																	
	<input type="checkbox"/>																																	
OFF	<input checked="" type="checkbox"/>	AZ																																
OFF	<input checked="" type="checkbox"/>	PRB																																
TRK	<input checked="" type="checkbox"/>	PEAK																																
ZRO	<input checked="" type="checkbox"/>	GAIN																																
V / C	<input type="checkbox"/>																																	
Lg / Sm	<input checked="" type="checkbox"/>																																	
	<input type="checkbox"/>																																	
FIL ▶	<input checked="" type="checkbox"/>																																	
 Toledo Integrated Systems Holland, OH Made in the USA Toledo Transducers, Inc.																																		

Figure 14: Calibration Card Sample

➤ Operation

Once the ZT-1 has been calibrated, it is ready for continuous use. This section details the setup for Peak Mode and Track Mode operations.

1) Peak Mode operation

In Peak Mode, the output will increase to the highest load level and remain at that voltage until the probe transitions from off to on again.

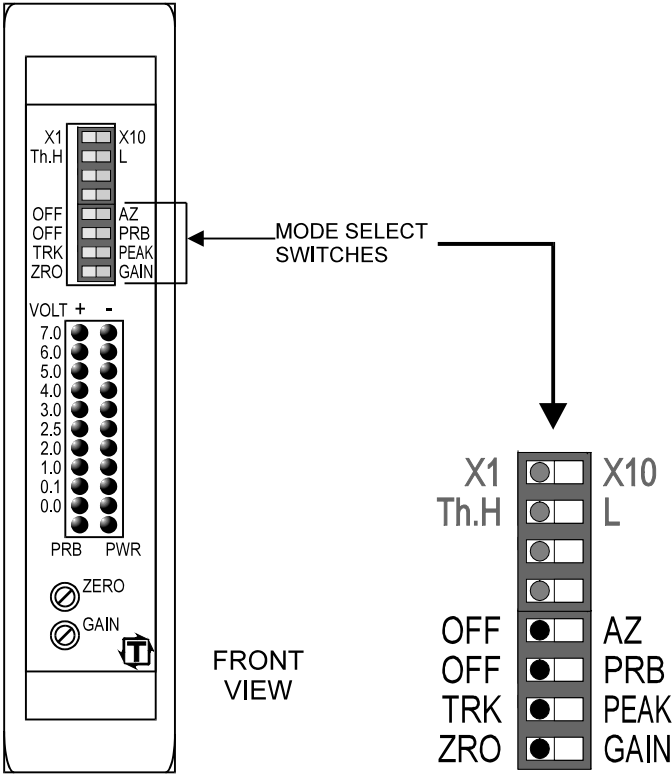

- 1) Set the Mode Select Switches to AZ OFF, PRB OFF, TRK, and ZRO as shown above.

- 2) Skip this step if Auto-Zero is not needed.
a) Toggle the OFF/AZ switch to AZ to start Auto-Zero.

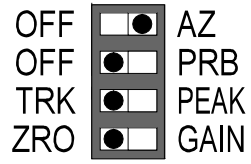

- b) When Auto-Zero is done, only the 2 yellow LEDs at 0.0V are lit.

- 3) Set the OFF/PRB switch to PRB and set the TRK/PEAK switch to PEAK.

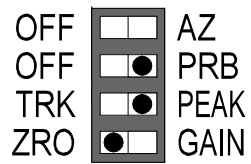

II) Track Mode operation

In Track Mode, output will follow the loading on the sensor as the load on the machine increases and decreases.

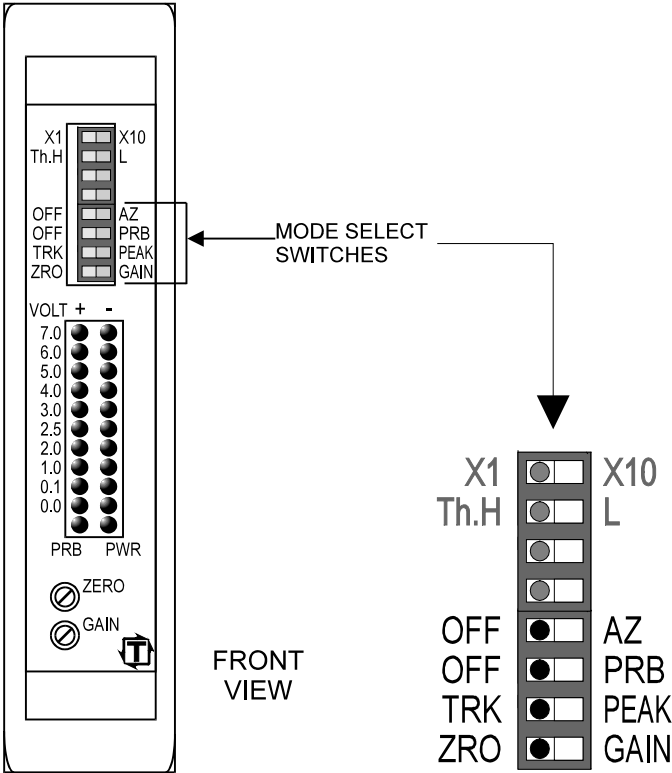

- 1) Set the Mode Select Switches to AZ OFF, PRB OFF, TRK, and ZRO as shown above. If Auto-Zero is not needed, it is done. Skip the following steps.
- 2) If Auto-Zero is needed, then
 - a) Toggle the OFF/AZ switch to AZ to start Auto-Zero.

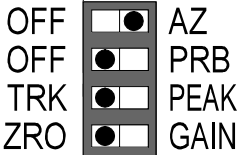

- b) When Auto-Zero is done, only the 2 yellow LEDs at 0.0V are lit.

3) Set the OFF/PRB switch to PRB.

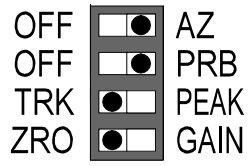

Appendix

- A) Sensor Installation (Doc# 11080)**
- B) Calibration Sheets (2) (Form# 1224)**

**THIS PAGE
INTENTIONALLY
LEFT BLANK**