

Toledo Transducers TR-1 Sine/Cosine Resolver

Specifications



Scan to visit us
on the web

Specifications for the TR-1 Resolver

Introduction

1.0 SCOPE

The purpose of this specification document is to describe the electrical characteristics of the Toledo Transducer's TR-1 Sine/Cosine resolver. It is strongly recommended that this document be read entirely before placing the TR-1 into operation. Failure to obey the electrical characteristic of the TR-1 may result in permanent damage to the unit or void the warranty.

Questions regarding any aspect of the TR-1 resolver should be referred to Toledo Transducers, Inc.:

Toledo Transducers, Inc.
6834 Spring Valley Drive
Holland, Ohio 43528

Phone: (419) 867-4170
Fax: (419) 867-4180

2.0 TR-1 SINE/COSINE RESOLVER FUNCTIONAL DESCRIPTION

The TR-1 resolver is specifically designed for long life, high rotational speeds, and vibration immunity. Its internal design is based upon a size 11 resolver, in conjunction with balanced bearings, giving it the ability to out perform other resolvers currently offered by other manufacturers in today's market. Figure 2.1 depicts the TR-1 resolver.

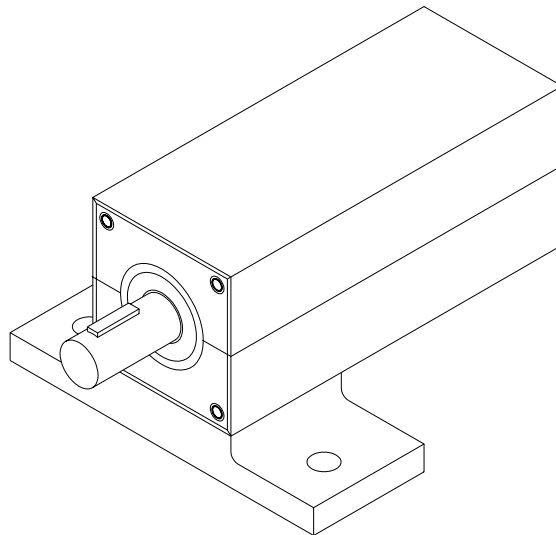

Figure 2.1 TR-1 Resolver Unit

Resolvers are essentially transformer based units, having both primary and secondary windings. The primary winding, as in a standard transformer, will be driven by an AC voltage source. The primary winding of the TR-1 is the rotor winding and is designated as R1 and R2. This winding will be driven by an external AC voltage source that typically has an amplitude of 7.0V rms with a frequency of 5000Hz. The other windings are

known as the stator and are designated as S1, S3, and S2, S4. It is from these windings that rotational data is presented. Figure 2.2 shows the electrical schematic of the TR-1.

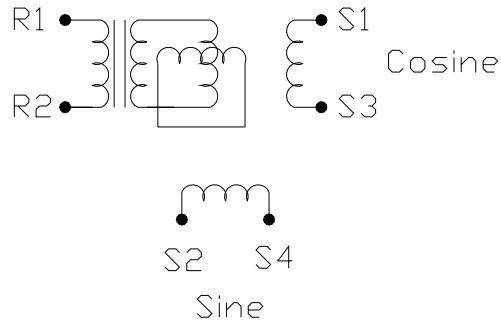

Figure 2.2 TR-1 Electrical Schematic

3.0 TR-1 SINE/COSINE RESOLVER CONNECTIONS

Figure 3.1 shows the electrical connections for the TR-1 resolver. The back connector of the TR-1 resolver is an Amphenol, 7 pin, male connector.

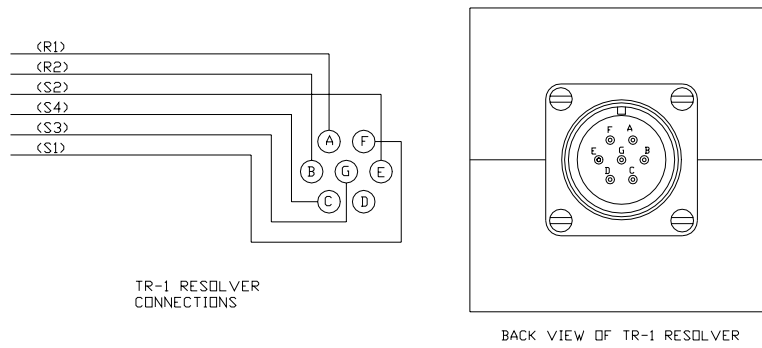

Figure 3.1 TR-1 Electrical connections

4.0 TR-1 SINE/COSINE RESOLVER ELECTRICAL CHARACTERISTICS

Table 4.1 shows the electrical characteristics for the TR-1 resolver

Input Voltage (Nominal)	7.0 Vrms
Input Frequency	5000Hz
Primary Winding	Rotor (R1, R2)
Input Rotor Current (max)	10.9 mA
Input Power	47 mW
Output Voltage (stator windings)	6.7 Vrms
TR (Transfer ratio)	.95
Phase Shift (open circuit) leading	-6 degrees
Sensitivity	116 mV per degree
DC Rotor resistance	16 ohms \pm 10% ohms
DC Stator resistance	52 ohms \pm 10% ohms
Total Null Voltage	15 mV
Accuracy Maximum Error	\pm 7 minutes

5.0 TR-1 SINE/COSINE RESOLVER MECHANICAL DIMENSIONS

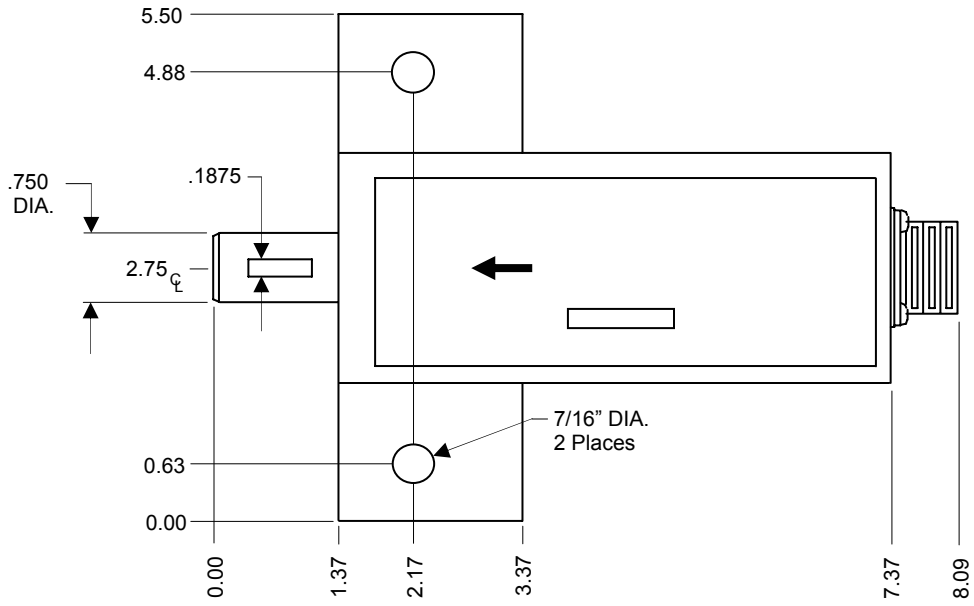

Figure 5.1 Top View

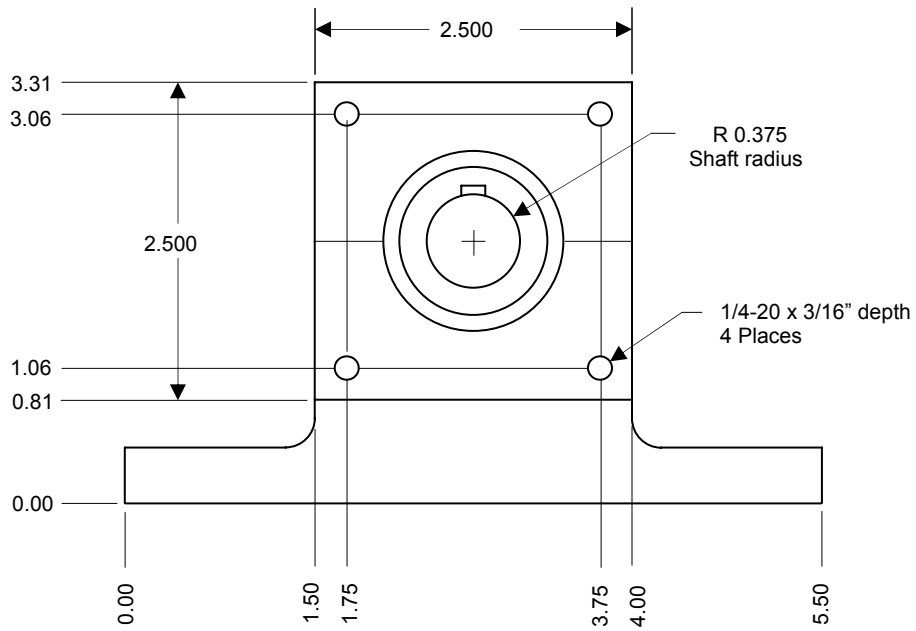

Figure 5.2 Front View