

SlimWare

Tonnage & Signature Software

Toledo Integrated Systems
Toledo Transducers, Inc.



Version: 4.3

Serial #: _____

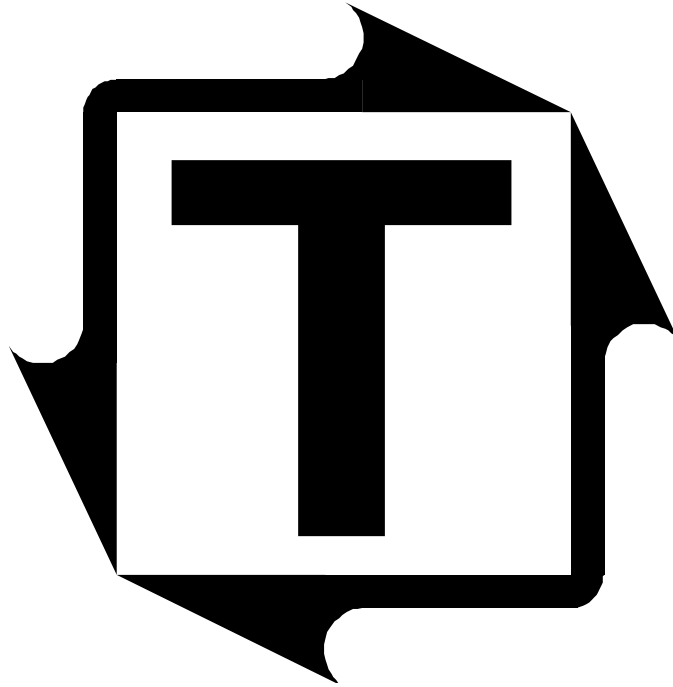

SlimWare 4.0 User's Manual

Revision: H



Scan to visit us
on the web

Table of Contents

Introduction	1
1 SlimWare Installation	2
2 Interface Connections	3
3 Starting SlimWare	4
4 SlimWare's Main Toolbar	6
5 Configuration Toolbar Function	7
6 SetPoints Toolbar Function	16
7 Details Toolbar Function	22
8 Statistics Toolbar Function	24
9 Signature Toolbar Function	26
10 Tonnage Toolbar Function	33
11 Virtual KeyPad Function	36
12 Lock Data Toolbar Function	37
13 Application Hot Key Function	39
14 SlimWare's Alarm Indications	40
15 Resolver Error Box	41

Table of Figures

2.1	RS485 Connections.....	3
2.2	RS232 Connections.....	3
3.1	Selecting the Correct PC Comm Port	4
3.2	Selected Comm Port is Unavailable	4
3.3	SlimWare Monitor Search Dialog Box.....	4
3.4	Monitor Search Error Dialog Box	5
3.5	SlimWare Tonnage Monitor Window	5
4.1	SlimWare's Main ToolBar	6
5.1	SLIM Monitor Window	7
5.2	SLIM Software Window.....	8
5.3	System Mode/Alarm Window	9
5.4	System Trigger/Autoset Window	11
5.5	System Calibration Window.....	13
6.1	SlimWare's Tonnage Monitor and System Setpoints Windows.....	16
6.2	System Setpoints Window - Capacity	17
6.3	System Setpoints Window - High Setpoints.....	18
6.4	System Setpoints Window - Low Setpoints	19
6.5	System Setpoints Window - Benchmark	20
6.6	System Setpoints Window - Counters	21
7.1	Tonnage Monitor and System Details Windows.....	22
7.2	System Details Functionality	23
8.1	Tonnage Monitor and System Statistics Windows.....	24
8.2	System Statistics Details.....	25
9.1	System Process Window.....	26
9.2	System Process Functionality	27
9.3	Recall Signature Prompt Box (Select From Monitor)	28
9.4	Signature Download in Progress Prompt Box.....	28
9.5	Downloaded Signature From Online Load Monitor.....	29
9.6	Recall Signature Prompt Box (Select From File).....	30
9.7	Recall Signature From File Prompt Box	30
9.8	Signature Retrieved From File	31
9.9	Save Signature To File Prompt Box	32

Table of Figures

10.1	Tonnage Monitor Window.....	33
10.2	Tonnage Monitor Window Details	34
10.3	Tonnage Monitor Window Details	35
11.1	Numeric Virtual Keypad	36
11.2	Alphanumeric Virtual Keypad	36
12.1	Data Locked Prompt	37
12.2	Password Entry Box	37
12.3	Data Locked icon in Unlocked State	37
12.4	Password Entry Box - How to Change the Active Password	38
12.5	Change User Password Entry Box	38
12.6	New Password Prompt Box	38
13.1	Invalid Application Call Prompt Box	39
14.1	SlimWare's Alarm Indications.....	40
15.1	Resolver Error Prompt Box	41



SlimWare

Introduction

Thank you for purchasing SlimWare, the latest software development from Toledo Integrated Systems that will enable you to easily interface to our line of Signature analysis load monitors.

SlimWare is a 32 bit Windows based software package exclusively developed for Toledo Integrated Systems' SLIM (Signature Load Interface Module) load monitor. SlimWare can also be used with the N260 series of load monitors, however this manual's main focus is toward the use of the Slim. When these load monitors are used in conjunction with resolver-based systems, the units are able to sample the process at each degree, thus allowing the process signature to be acquired and digitized. When these load monitors are used in conjunction with SlimWare, control of the monitor, and analysis of your process's signature are only a touch away.

SlimWare has been designed with touch screen computers in mind. Each screen of the user interface is easily navigated through the use of toolbar buttons and large icons for high visibility. Ease of use was an important factor in the development of this software package.

Before you begin the installation of SlimWare, the following recommendations and notices are given:

- You should be familiar with Microsoft's Windows operating system. (Windows 95, 98, 2000, XP, Vista or NT 4.0)
- You should be familiar with using a mouse as a pointing device.
- Your PC should have Windows 95, 98, 2000, XP, Vista or NT 4.0 (or later). SlimWare will not function in a DOS or Windows 3.1 environment.
- Your PC should have at least a 133Mhz Pentium or equivalent. Since SlimWare is graphic intensive, performance degradation may be noticeable on systems that have 486-based processors.
- Your PC should have at least 32Mb of memory
- Your PC display should have at least 640 x 480 resolution with at least 256 colors. SlimWare was exclusively developed for touch screen computers with 640 x 480 flat panel displays that have the ability to display 256 colors. If your display device has a higher resolution than 640x480, it is highly recommended to use SlimWare at a resolution of 800 x 600 with a color depth of 65536 (high color). Unpredictable results can occur if the resolution is 1024 x 768 or higher.
- Your PC hard drive should have at least 15 Meg of available space.
- Your PC must have a mouse or Touch screen interface. SlimWare was developed for touch screen and/or mouse driven systems. Some keyboard functions are not implemented.
- Your PC must have a RS232 port or a RS485 port. The available ports are Comm1 through Comm4. If your PC fits the above recommendations, then you're ready to install SlimWare.

1 SlimWare Installation

SlimWare is distributed on one CD (compact disc). To begin the SlimWare installation, follow these steps:

- Close all programs that are currently running.
- Insert the CD into the **D:** (CD drive). (If auto-play is enabled, skip the next step)
- Select **My Computer** and then right click on the **D:** (CD Drive) and select **Open**.
- Double-click on **Setup.exe**. The installation of SlimWare will begin.
- Follow the directions given. **It is highly recommended that the default directory of C:\Program Files\SlimWare (where C: represents the hard drive designation on your computer) be used as the installation destination for the software.**

The installation of SlimWare may be stopped at any time and resumed later. To resume the installation process, simply repeat the above steps.

2 Interface Connections

After the SlimWare installation has been completed, your PC's serial data port must be connected to the serial data port of the Slim load monitor that is designated as RS485-1. If your PC has a RS485 port, refer to Figure 2.1 for the correct connections to the Slim. If your PC has a RS232 port, refer to Figure 2.2 for the correct connections to the Slim.

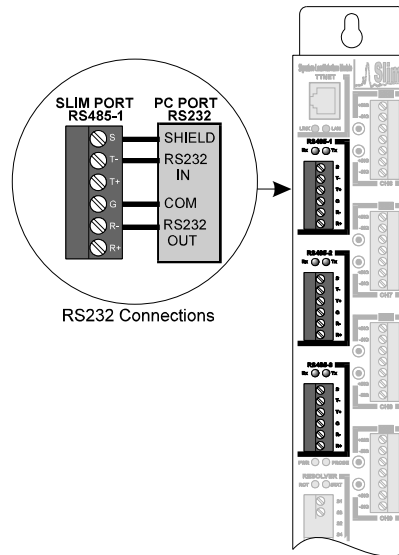
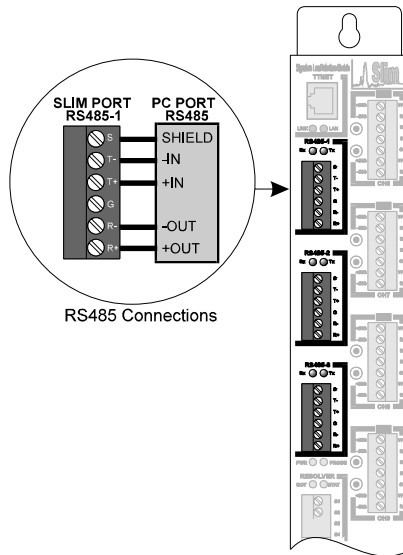

Figure 2.1 - RS485 Connections

Figure 2.2 - RS232 Connections

After the appropriate connections have been established between the PC serial data port and the Slim load monitor, SlimWare is ready to be started. Follow the instructions in the next section to begin using SlimWare.

3 Starting SlimWare

To begin using SlimWare, click on Window's Start button (usually in the lower left corner of the task bar) . From the fly out menu, select All Programs, then select SlimWare. The **Comm Port Selection** dialog box will appear as shown in Figure 3.1.



Figure 3.1 - Selecting the correct PC Comm Port or Viewer Mode

Click the Comm Port button that represents the physical connection between your PC Comm Port and the SLIM load monitor or select Viewer Mode (no load monitor connected). Once you have selected the correct Comm port, click **Enter** to continue. If you select a Comm port that is not supported in your PC, or if the serial data port is already in use, SlimWare will inform you of the error as shown in Figure 3.2. Choose "Continue" to select another COMM port, or "Exit" to quit SlimWare and return to the desktop. Selecting Viewer Mode will permit the use of program without load monitor connected for viewing signatures (other functions inoperative without load monitor connection).

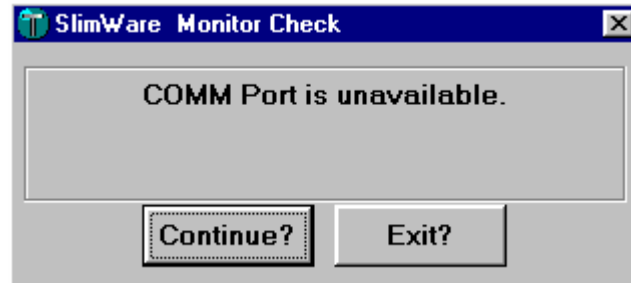

Figure 3.2 – Selected Comm Port is Unavailable

If your PC supports the Comm port selected, the **Monitor Search** dialog box will appear as shown in Figure 3.3. SlimWare is now actively searching for an online Slim load monitor. During this phase of the software operation, SlimWare will search for an online Slim load monitor at addresses 0 through 31 using baud rates of 9600, 38400, and 115200. The progress bar indicates the status of the search. This search can take several minutes to complete if the address of the monitor is 31, and the unit's baud rate is 115200.

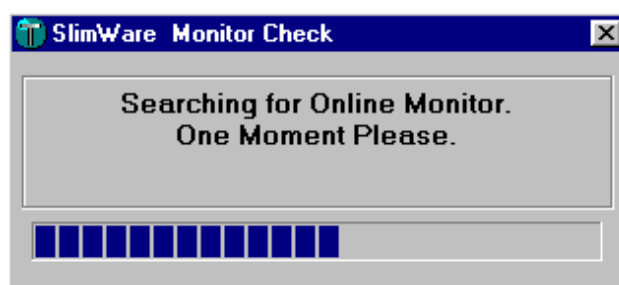

Figure 3.3 - SlimWare Monitor Search Dialog Box

3 Starting SlimWare – continued

If SlimWare finds that there is no Slim load monitor attached when a comm port is selected, a **Monitor Search Error** will occur as shown in Figure 3.4. If this happens, determine if the Slim load monitor has power applied. If power is applied, then check all connections between your PC and the Slim load monitor. If the connections appear to be correct, then make sure the correct PC Comm port was selected. Click OK to close the **Monitor Search Error** box, then restart SlimWare to resume a new search.

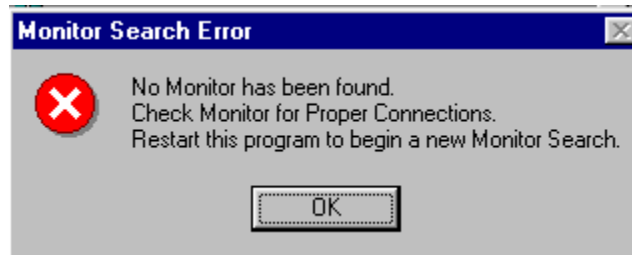

Figure 3.4 - Monitor Search Error Dialog Box

If SlimWare is successful at finding an online Slim load monitor, the address and detected baud rate will be verified and the main SlimWare module will be loaded as shown in Figure 3.5 (except in Viewer Mode).

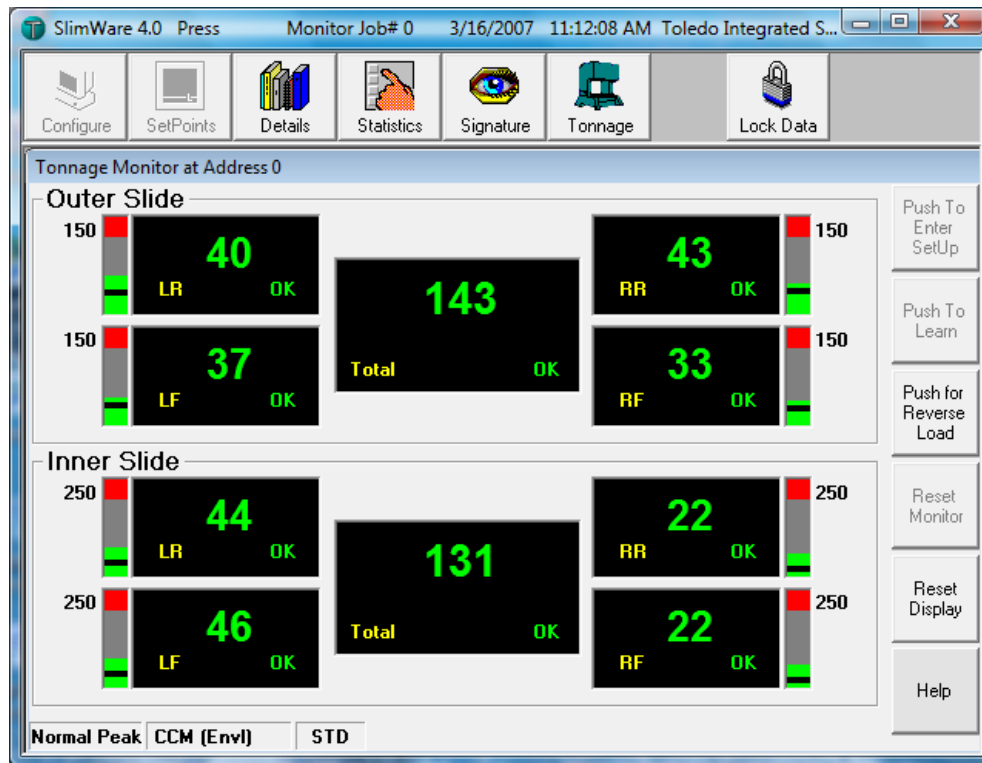

Figure 3.5 – SlimWare Tonnage Monitor Window

The screen displayed may differ than that shown, depending on whether the online Slim load monitor is a four channel unit or an eight channel unit. At this point, SlimWare is fully loaded and functional. SlimWare can now be used to monitor your application.

4 SlimWare's Main Toolbar

Figure 4.1 depicts the main toolbar of SlimWare. Directly above the main toolbar, resides the main title bar of SlimWare. This title bar contains the latest software revision number, the press number that SlimWare has been configured to monitor, the current job number of the monitor, the current date, and the current time. When a toolbar is selected, that button's associated window will appear. Menu buttons are enabled/disabled according to password level. Supervisor/Master password level will display all buttons. Setup password level will display all buttons except Configure. The Operator password level will display all buttons except Configure and SetPoints. Details of each toolbar function are explained in the sections that follow.

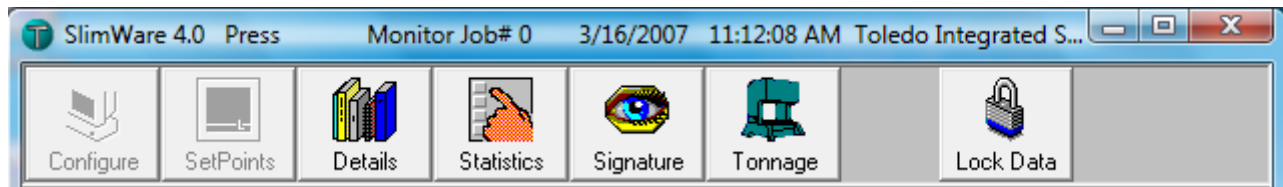

Figure 4.1 - SlimWare's Main Toolbar

5 Configuration Toolbar Function (SLIM Monitor)



The **Configuration** toolbar function provides numerous options dealing with the monitor, software, system mode parameters and calibration. The configuration page is divided into five tabs. The first tab enables the SLIM Tonnage Monitor Configuration window as shown in Figure 5.1. The SLIM Tonnage Monitor Configuration is used to initially set up the online Slim load monitor. It is also used as a quick reference guide as to how the online Slim load monitor is configured. The configuration toolbar is password protected and can only be accessed with a Supervisor/Master password.

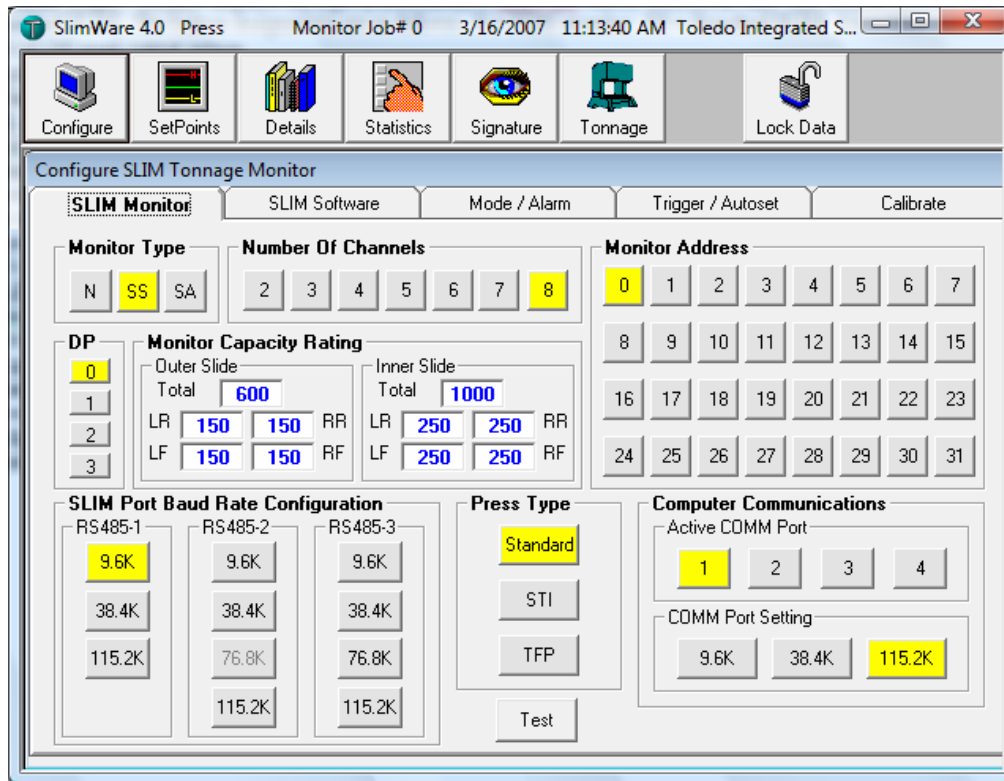

Figure 5.1 - SLIM Monitor Window

Monitor Type: Defines/displays the type of load monitor SlimWare will be interfaced with. The default monitor type is Standard SLIM. The button designations are as follows: N = N260 monitor SS = Standard SLIM SA = Slim with ANALOG peak output option.

How Many Channels: Defines/displays the number of channels the online load monitor has been configured for.

What Monitor Address: Defines/displays the communication address of the online load monitor.

DP: Defines/displays the number of decimal places the online load monitor will use in displaying load values and related data.

Monitor Capacity Rating: Defines/displays the maximum load values per channel that the online load monitor is configured for. For eight channel units, the inner slide values become active. To change the capacity rating of the online load monitor, select the channel of interest, then enter the value. If data is entered into the Total box, the capacity value will be equally divided amongst the channels. As an example, if you enter 1000 into the Total box, the other channels will equal 250. If you have an eight channel load monitor, capacity values are entered separately for the outer and inner slides.

SLIM Port Baud Rate Configuration: Defines/displays the baud rate settings for the three communication ports of the Slim load monitor. This parameter field is unavailable if the N260 type monitor is selected in the Monitor Type box. The HMI port is associated with the Slim port designated as **RS485-1**.

Type of Press: Displays the type of press SlimWare is monitoring. STI and TFP are currently not supported.

Computer Communications: Displays the host computer's serial data port number and baud rate settings that SlimWare is configured for. Port number is determined at SlimWare startup. Baud rate is determined by HMI port baud rate settings.

Help: Available online help for the SLIM Configuration page.

Test: Factory test unavailable to end users. Factory authorized password is needed to gain access.

Doc #: 11463



5

Configuration Toolbar Function (SLIM Software)



Selecting the **SLIM Software** tab enables the Configure SlimWare window as shown in Figure 5.2. The SlimWare configuration window is used to initially set up SlimWare and configure user permission. Parameters within this window are Supervisor/Master password protected.

The screenshot shows the 'Configure SLIM Tonnage Monitor' window with the 'SLIM Software' tab selected. The window is divided into several sections:

- Application HotKey Options:** Includes a checkbox for 'Use Application Hot Key', an 'Application Name' field, and a 'Hot Key Label' field set to 'HOME'.
- Signature Analysis Options:** Includes a checked checkbox for 'Automatic Retrieval every 7 strokes. Press should not exceed 84 SPM.', a checked checkbox for 'Automatic Save', and a note: 'Note: Will retrieve every 5 seconds if SPM are exceeded. Use 38.4K baud or faster for Auto Retrieval feature.'
- Job Data And Password Management:** Includes four checked checkboxes: 'Enable External Job Data Management', 'Enable Lock Key Management', 'Enable Alarm Reset Without Password', and 'Enable Exit Without Password'.
- Virtual Keypad Options:** Includes an unchecked checkbox for 'Enable Virtual Keypad for Touchscreens'.
- Visual Options:** Includes a checked checkbox for 'Allow SlimWare to be minimized.' and an unchecked checkbox for 'Maximize Slimware (Slimware Restart Required)'.
- Password Options:** A table with columns for 'SETUP' and 'OPERATOR' and rows for 'Reset Alarms' and 'Data Entry', all with unchecked checkboxes.
- Press Slide Descriptions:** Two text input fields: 'Ch0 - Ch4.... Outer Slide' and 'Ch6 - Ch9.... Inner Slide'.

Figure 5.2- SLIM Software Window

Application HotKey Options: Selecting this option enables the use of the application hotkey. Using the hotkey will bring another application to the foreground. You must enter the application name in the 'Define Application Name' data field. The 'Hot key Label' data field is the name that appears in the title bar of the running application.

Signature Analysis Options: Selecting "Automatic Retrieval" enables or disables the automatic retrieval of signature data from the online tonnage monitor. If this option is selected, signatures will be automatically retrieved at selected SPM intervals. Maximum SPM are listed for a given stroke interval. Selecting "Automatic Save" will also automatically save signatures to a file if automatic signature retrieval is also turned on.

Job Data And Password Management Option

Enable External Job Data Management: This option is used with our Maximizer software. This will allow the use of login/data information to be input through external configuration files.

Enable Lock Key Management: Checking this will keep the lock key button enabled. You can disable this so that the only way to login or logout is through an external configuration file.

Enable Alarm Reset Without Password: This option allows the user to reset alarms without a password. This is intended for setup purposes only.

Enable External Job Data Management: Under normal conditions, to close Slimware a user needs to be logged in or input the correct password. Checking this option will allow Slimware to close without being logged in or prompted for a password.

Virtual Keypad Options: Selecting this option will allow the virtual keypad to be displayed each time a data entry box is selected. This option is usually used with systems that have a touch screen as the user interface.

Visual Options

Allow Slimware To Be Minimized: Checking this will allow a user to minimize Slimware.

Maximize Slimware: Slimware can be maximized to take up the entire screen. Checking this will maximize Slimware.

Password Options

Reset Alarms: If this option is selected, the listed password level user (SETUP or OPERATOR) can reset alarms.

Data Entry: If this option is selected, the SETUP level password user can enter data.

Press Slide Descriptions: Entering data into these data fields allows the user to change the descriptions of the slides.



5 Configuration Toolbar Function (Mode / Alarm)



Selecting the **Mode / Alarm** tab enables the System Mode Parameters window as shown in Figure 5.3. The System Mode Parameters window is used to display and change operating modes, alarm enabling settings, and various other features incorporated into the online load monitor. Parameters within this window are Supervisor/Master password protected.

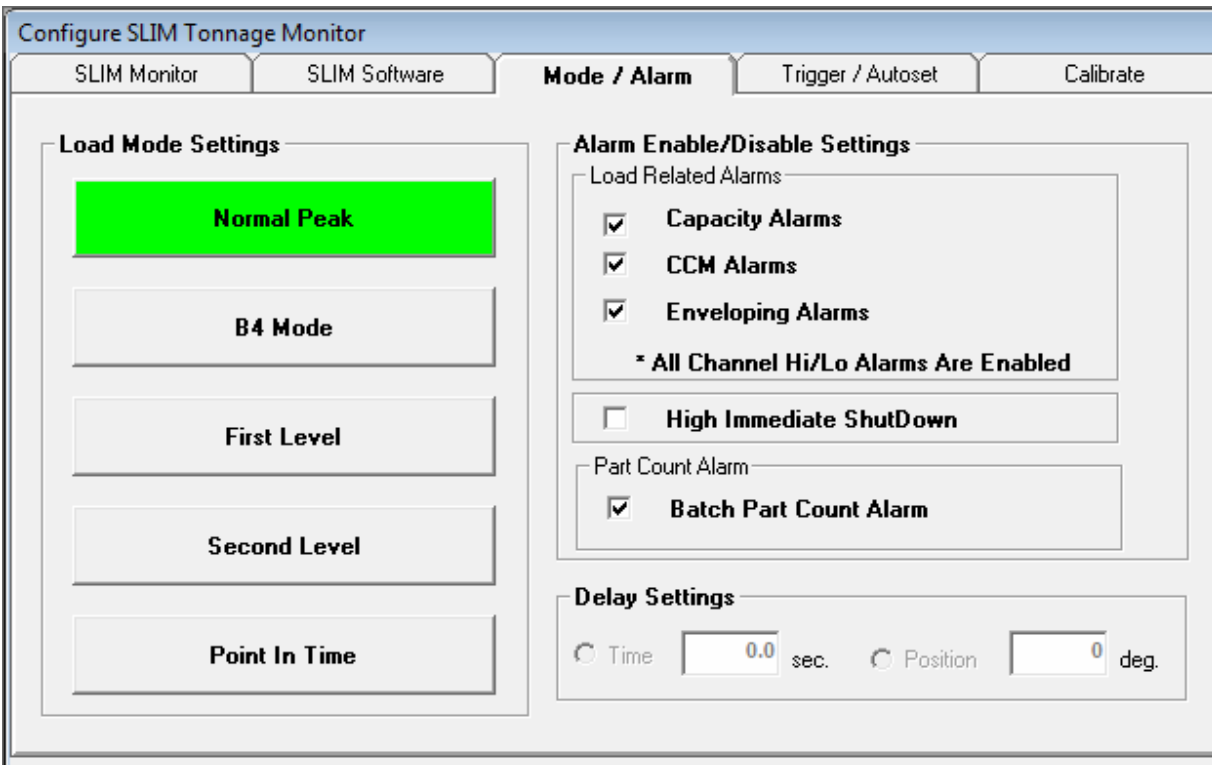

Figure 5.3 - System Mode/Alarm Window

Load Mode Settings

Normal Peak: Clicking this button places the online monitor into peak mode. This mode of operation acquires the input signal and displays the highest load value during the press cycle. A Green highlighted button indicates Normal Peak mode is active.

B4 Mode: Clicking this button places the online monitor into time mode B4. B4 mode displays the distributed forces at the first level time in channels 1 through 4 (LR-RF). When the punch completes the stroke, the total load is displayed. B4 mode only applies to four channel monitors. A Green highlighted button indicates B4 mode is active.

First Level: Clicking this button places the online monitor into time mode 1. The First Level loading is the peak load which occurs from the initial threshold crossing, up to a specified time or specified angle. The time or angle values are entered under the Delay Settings heading. A Green highlighted button indicates First Level mode is active.

Second Level: Clicking this button places the online monitor into time mode 2. The Second Level loading is the peak load which occurs between a specified time or angle and the end of the stroke. The time or angle values are entered under the Delay Settings heading. A Green highlighted button indicates Second Level mode is active.

Point In Time: Clicking this button places the online monitor into time mode 3. Point in time mode informs the monitor to display the load at a particular point in the stroke, based on a time or angle position that is entered under the Delay Settings heading. An external probe can also be used to trigger Point in Time mode. A Green highlighted button indicates Point in Time mode is active.

Alarm Enable/Disable Settings

Capacity Alarms: Checking this box enables or bypasses the Capacity Alarms of the online load monitor. If the box is checked, the alarms are active. If the box is unchecked, the alarms are bypassed.

CCM Alarms: Checking this box enables or bypasses the CCM Alarms of the online load monitor. If the box is checked, CCM alarms are active and anytime the press curve setpoint is violated, the shutdown relay will activate. If the box is unchecked, CCM alarms are bypassed and press curve setpoint violations will be ignored. If the text is dimmed, CCM monitoring is disabled and the CCM Immediate

ShutDown box is not visible. Checking the CCM Immediate ShutDown box when CCM Alarms are active will either enable the shutdown relay to activate immediately when the alarm occurs, or will enable the relay to activate after 290 degrees of the press stroke takes place. If the CCM Immediate ShutDown box is checked, CCM shutdown is immediate. If the box is unchecked, CCM shutdown occurs after 290 degrees.

Envelope Alarms: Checking this box enables or disables Enveloping Alarms. If the box is checked, anytime an envelope violation occurs, the shutdown relay will activate. If the box is unchecked, Enveloping Alarms are bypassed and Enveloping Alarms will be ignored. If the text is dimmed, Enveloping is disabled.

***All Channel Hi/Lo Alarms Are Enabled:** This indicates the status of alarm bypassing of the individual channels. If the text reads "All Hi/Lo Alarms Are Enabled", all individual channel alarms are active. If the text reads "At Least One hi/Lo Alarm is Disabled", some type of channel alarm has been bypassed. To view the status of channel alarms, view the channel setpoints accessed by the SetPoints button on the main toolbar.

High Immediate Shutdown: Checking this box enables or bypasses the High Immediate ShutDown. If the box is checked, when the alarm relay is activated, the press will immediately shutdown. If the box is unchecked and the alarm relay is activated, the press will stop after 290 degrees.

Batch Part Count Alarm: Checking this box enables or bypasses the Batch Set Alarm. If the box is checked, anytime the batch set count is reached the shutdown relay will activate. If the box is unchecked, the Batch Set Alarm will be ignored when the batch set count is reached. See the SetPoints/Counters section for details on setting the Batch Set count value.

Delay Settings

Time: This option is enabled when load mode is anything but Normal Peak. This setting is used to set the time value in seconds.

Position: This option is enabled when load mode is anything but Normal Peak. This setting is used to set the position value in degrees.



5 Configuration Toolbar Function (Trigger / Autoset)



Selecting the **Trigger/Autoset** tab enables the System Mode Parameters window as shown in Figure 5.4. This window is used to control trigger settings, enable autoset and enveloping modes and configure the enhanced autoset settings. Parameters within this window are Supervisor/Master password protected.

Figure 5.4 - System Trigger/Autoset Window

AutoSetSettings

The Enable Autoset function controls how the online Slim load monitor will calculate automatic setpoint values. Two modes of Autoset are available. These modes are standard Autoset, and Envelope Autoset. When standard Autoset is enabled, the online load monitor will calculate a benchmark value after eight strokes of the press cycle have occurred. Once the benchmark is established, high and low alarm limits are then calculated, based on a specified percentage value. The calculation of the high and low alarm limits can either be based upon a percentage of the capacity of the press, or as a percentage of the benchmark value. If Autoset is disabled, high and low alarm limits can be entered manually. See the "SetPoints ToolBar Button" for a detailed explanation on how to enter high and low alarm limits and the specified percentage value for use in Autoset modes.

The Enable Envelope Autoset function operates in much the same manner as standard Autoset except the high and low alarm limits are calculated at each degree of the input signal, beginning at 35 degrees and ending at 290 degrees. In order for this function to operate correctly, a resolver must be used as the triggering device to the online load monitor. This function must be enabled in order to view enveloping with signature.

Enable AutoSet: Clicking this box will enable or disable AutoSet mode for the online load monitor. When Autoset is active, high and low alarm limits are automatically established after eight press strokes have occurred.

If Autoset is disabled, high and low alarm limits can be entered manually by selecting the SetPoints button on the main toolbar.

% of Capacity: Clicking this button will base the high and low alarm limit calculation upon a specified percentage of the press capacity.

% of Benchmark: Clicking this button will base the high and low alarm limit calculation upon a specified percentage of the established benchmark value.

Enable Enveloping Mode: Clicking this button will enable Envelope AutoSet mode.

Trigger Settings

Threshold Trigger: Clicking this box will place the online load monitor into Threshold Mode. Threshold is the minimum total load which must be generated in channel 0 before the signal is recognized as a load signal. The threshold value can be changed by entering a

new value in the data entry box under the Threshold Value heading. If Threshold Mode is the active mode of triggering, the button will be highlighted Green. If Threshold Mode is not active, the button is not highlighted and threshold values cannot be entered.

Resolver Trigger: Clicking this box will place the online load monitor into CCM Mode. CCM Mode (Critical Curve Monitoring) requires the use of a resolver for triggering. At each degree of the press stroke, signal data is acquired and analyzed for press curve setpoint violations. Anytime the load signal crosses the boundary of press curve data, a CCM alarm is generated, as long as CCM alarms are not bypassed. When CCM Mode is the active mode of triggering, the button is highlighted and information for Resolver Data becomes available. The resolver offset can be set by entering data in the Offset data entry box. CCM Mode forces the Threshold Value to the capacity value of channel 0.

Probe Trigger: Clicking this box places the online load monitor into Threshold Probe Mode. This mode of triggering requires the use of an external probe. When the external probe is active, signal data is acquired. When Threshold Probe Mode is active, the button will be highlighted.

Threshold Value: Displays the current Threshold Value.

Resolver Data: Displays the current angle and offset data for the resolver. Offset data can be changed to align the resolver to the correct angle.

Enhanced AutoSet Settings: The Enhanced AutoSet sub-function is used in conjunction with Toledo Integrated Systems' PressNet program. In order for this sub-function to operate correctly, users must have the cookbook feature of PressNet installed on their main PC server. Enhanced AutoSet has been implemented for future compatibility with PressNet. If you do not have PressNet's cookbook feature, the Phase 1 and Phase 3 parameters should be set to zero. See the PressNet user's manual for details on the functionality of Enhanced AutoSet.

5 Configuration Toolbar Function (Calibration)



Selecting the **Calibration** tab will enable the System Calibrate window as shown in Figure 5.5. The System Calibrate window is used to display or change the current sensor balance and gain levels of the online Slim load monitor. The System Calibrate window is explained in detail below. Accompanying the explanation, is an outline of the calibration steps needed to successfully interface the online Slim load monitor to loadcells or strain link sensors.

Displays the current Calibration Data for the Outer and Inner Slides (Ch0 through Ch9). Each channel's data is displayed as a percentage of its capacity value. If the online load monitor has four channels or less, the Inner Slide data is not visible. When AutoBalance is active, the information displayed represents the zero balance level of the monitor's sensor inputs. When the sensors are balanced, the "Zero" prompt is highlighted in Green. When the Shunt is engaged, the information displayed represents the current gain number of the associated channel.

If AutoBalance and Shunt are not active, the information displayed represents the current load data.

Displays the current load level, zero balance level, or gain number of the associated channel. Gain numbers for the Total of the Outer and Inner slides cannot be entered. To change the gain number of a specified channel, click the Enable SHUNT button. The Shunt button will highlight to Yellow and the button prompt will change to Disable SHUNT. Select the channel of interest by clicking the associated data entry box. Type in the new gain number, then select the Enter key to accept the new value. Because of round off errors, the gain number may have to be entered several times until the desired value is achieved. See "Calibration of Slim Load Monitors" in this section, for complete details on the calibration procedure.

Clicking this button will automatically establish the zero balance level of the attached sensors. When AutoBalance is active, this button will be highlighted in Yellow, and the button prompt will change to "Auto Balance On".

Clicking this button will engage a shunt resistor across the sensor input. When this mode is active, the button will be highlighted in Yellow and the prompt will change to "Disable Shunt". This mode allows the current gain number per channel, to be viewed or changed.

Figure 5.5 - System Calibrate window

5 Configuration Toolbar Function (Calibration – Cont.)

Calibration of Slim Load Monitors

Load Cell Calibration

When a precalibrated load cell is used as the input sensor for a particular channel, the calibration number has been previously determined at the factory. The value of this number is dependent upon the value of the shunt resistor used during the load cell's calibration procedure. The number is normally included in a specification sheet that is shipped with each load cell. If the calibration number was derived from a shunt resistor other than one megohm, a mathematical conversion must be made. When the calibration number has been determined, the Balance and Gain values of the online load monitor, must be adjusted to match this number in order to obtain the correct results from the load cell.

To obtain the new calibration number, perform the following steps.

- If the calibration number of the load cell is based upon a one-megohm resistor, the number will correlate directly with the online monitor's internal one megohm shunt resistor. This number can be used without modification as the gain number of the selected channel.
- If the calibration number of the load cell is not based upon a one megohm resistor, a new number must be calculated by using the following formula:

$$\text{New Cal Number} = \frac{\text{Old Cal Number} \times \text{Load cell's calibration shunt resistor value}}{1,000,000}$$

This new number will be used as the gain number of the selected channel. Refer to Figure 9.1 for details of the System Calibrate window.

5 Configuration Toolbar Function (Calibration – Cont.)

Calibration of Slim Load Monitors

Strain Link Calibration

- Connect the sensors to the correct channel (Left Rear sensor to Left Rear channel, etc.). Refer to the Slim user's manual for correct sensor installation.
- Set the press capacity of the press (rated maximum load) by proceeding to the System Configuration window (select Configure on the main toolbar). Refer to the **Configuration ToolBar Button** section of this manual for instructions to enter capacity values. After the capacity value(s) have been entered, return to the System Calibration window (select Calibrate on the main toolbar).
- Torque each sensor while watching SlimWare's System Calibrate window. Verify that the sensor and the online monitor's channel position correlate (Left Rear sensor equals Left Rear channel). If the channels do not correlate, they must be moved to the correct channel before proceeding.
- Set the trigger mode of the monitor by proceeding to the System Mode/Trigger Settings window. Refer to Figure 5.4 for details. When the trigger mode has been selected, return to the System Calibration window by selecting the Calibrate button on the main toolbar.
- Adjust the zero balance of each sensor by clicking the "Set AutoBalance" button. SlimWare will inform the Slim monitor to automatically adjust the zero balance of each channel. The AutoBalance button will highlight to Yellow. When AutoBalance completes, the button will return to Grey.
- Determine the correct shut height of the press.
- Place Toledo Transducer's AutoCells on to the bed of the press. Make sure all AutoCells are properly positioned and equally spaced from side to side, and from front to rear. AutoCells are typically placed at each corner of the press's bed. Place cardboard on top of, and beneath the AutoCell (**Please refer to Toledo Transducers AutoCell User's Manual for details**).
- Select Details from the main toolbar to display the Tonnage Monitor window. Place the online Slim load monitor into Setup Mode by selecting the **Push To Enter Setup** button. Enter the current password when requested. When the monitor enters Setup Mode, the button will highlight to Yellow. Once the monitor enters Setup Mode, cycle the press and hit the AutoCells. Take notice of the AutoCell's displayed value. This is the load value of the press corner. Take note of the values displayed on SlimWare's tonnage monitor, then return to the Calibration window.
- Enable the online load monitor's shunt by selecting the Enable SHUNT button. The button should highlight to Yellow. Select the data entry box of the channel of interest. Take note of the displayed values in the data entry boxes. The values displayed are the current gain numbers.
- Use the following formula to determine the new gain number:
(AutoCell reading/Load Monitor reading) x Current Gain Number = New Gain Number
 Type in the new gain number value into the selected channel's data entry box. Select the Enter key on the PC's keyboard when complete. If SlimWare's virtual keyboard is enabled, use its Enter key when gain number data entry is complete.
- Re-adjust the zero balance of the sensors by selecting the "Set AutoBalance" button.
- This completes a typical calibration of a strain link based system. Contact Toledo Integrated Systems Service Department for assistance if needed. Our Service Department can be reached at 419-867-4170, Monday through Friday, 8:00 AM to 5:00 PM.

6 SetPoints Toolbar Function



The **SetPoints** toolbar function will enable the small Tonnage Monitor window and the System SetPoints window as shown in Figure 6.1. The Tonnage Monitor window displays the latest load data, while the System SetPoints window is used to display and change alarm limits, benchmark percentage values, and counter parameters. The System SetPoints window is divided into five sub-functions. These sub-functions are **Capacity, High Setpoints, Low Setpoints, Benchmark, and Counters** (Counters is unavailable when using the Application Hot Key). When a sub-function is selected, the parameters of that sub-function become available to the user. You must have a setup access level before the System SetPoints window can be accessed. See the **Lock Data** toolbar function for password entry instructions. The details of the System SetPoints sub-function follows.

The screenshot shows the SlimWare 4.0 interface with the following components:

- Toolbar:** Configure, SetPoints, Details, Statistics, Signature, Tonnage, Lock Data.
- Tonnage Monitor at Address 0:**
 - Outer Slide:**
 - OK LR: 58
 - OK RR: 40
 - OK Total: 146
 - OK LF: 31
 - OK RF: 25
 - Inner Slide:**
 - OK LR: 42
 - OK RR: 23
 - OK Total: 129
 - OK LF: 45
 - OK RF: 23
 - Normal Peak | CCM (Envl) | STD
- System SetPoints:**
 - Outer Slide HIGH ALARM SetPoints:**
 - Total: 305
 - LR: 98
 - RR: 79
 - LF: 71
 - RF: 64
 - Inner Slide HIGH ALARM SetPoints:**
 - Total: 327
 - LR: 92
 - RR: 73
 - LF: 95
 - RF: 73
 - Help
 - Capacity | **High Setpoints** | Low Setpoints | Benchmark | Counters

Figure 6.1 - SlimWare's Tonnage Monitor and System SetPoints Windows.

6 SetPoints Toolbar Function - Capacity



System SetPoints Window

The **System SetPoints** window is used to display or set the various alarm limit values and operating parameters of the online Slim load monitor. Figure 6.2 details the Capacity sub-function. Capacity values cannot be changed from this window. Capacity values can only be changed from the SLIM Monitor tab in the Configuration window. See the **Configuration ToolBar Function** (pg. 7) for instructions on how to enter Capacity values.

System SetPoints Window - Capacity

Displays the Capacity setpoint values for the Total, LR, RR, LF, and RF corners of the press being monitored. If the online monitor has more than four channels, the Outer Slide Capacity values are displayed.

Displays the Capacity setpoint values for the Inner Slide of the press being monitored. If the online monitor has four channels or less, the Inner Slide Capacity values are not visible.

Clicking this button displays the online help for the Capacity Settings function of the System Setpoints Window.

Outer Slide CAPACITY Settings				
Total	LR	RR	LF	RF
600	150	150	150	150

Inner Slide CAPACITY Settings				
Total	LR	RR	LF	RF
1000	250	250	250	250

Help

Capacity High Setpoints Low Setpoints Benchmark Counters

Figure 6.2 - System SetPoints Window - Capacity

6 SetPoints Toolbar Function – High Setpoints



System SetPoints Window - High SetPoints

The **High SetPoints** sub-function allows the high alarm limits of the online Slim load monitor to be displayed or changed. Individual channel alarms can be disabled by simply clicking the alarm enable/disable box directly above the channel of interest. The occurrence of high alarms are ignored in those channels that have their high alarm monitoring disabled. To re-enable a high alarm for a particular channel, simply re-click the alarm enable/disable box that is associated with the channel of interest. A Master/Supervisor password is required to disable the alarm. A setup password or higher is needed to change the high setpoint values. Figure 6.3 details the High SetPoint sub-function of the System SetPoints Window.

Clicking any of the boxes above a channel data box will enable or disable a high alarm setpoint on the associated channel. A check mark in the box indicates the alarm has been disabled. To enable an alarm that has been disabled, click the box again. A "clear" box indicates the alarm is active

Displays the High Alarm Setpoint values for the Total, LR, RR, LF, and RF corners of the press being monitored. Also displays if the alarm is enabled or disabled. If the online monitor has more than four channels, the Outer High Alarm Setpoint values are displayed. To change a high alarm setpoint value, click the data box of the channel of interest, type in the new value, then select the "Enter Key" to complete the task. Values entered into the Total data box will be equally divided amongst the other channels.

Displays the High Alarm Setpoint values for the Inner Slide of the press being monitored. If the online load monitor has four channels or less, the alarm setpoints for the Inner slide are not visible. To change a high alarm setpoint value, click the data box of the channel of interest, type in the new value, then select the "Enter Key" to complete the task. Values entered into the Total data box will be equally divided amongst the other channels.

Clicking this button displays the online help for the High Alarm Setpoints function of the System Setpoints Window.

System SetPoints

Outer Slide HIGH ALARM SetPoints

<input type="checkbox"/> Total	<input type="checkbox"/> LR	<input type="checkbox"/> RR	<input type="checkbox"/> LF	<input type="checkbox"/> RF
229	73	60	53	48

Inner Slide HIGH ALARM SetPoints

<input type="checkbox"/> Total	<input type="checkbox"/> LR	<input type="checkbox"/> RR	<input type="checkbox"/> LF	<input type="checkbox"/> RF
327	92	73	95	73

Capacity
High Setpoints
Low Setpoints
Benchmark
Counters

Figure 6.3 - System SetPoints Window - High Setpoints

Doc #: 11463

Toledo Integrated Systems

6 SetPoints Toolbar Function – Low Setpoints



System SetPoints Window - Low SetPoints

The **Low SetPoints** sub-function allows the low alarm limits of the online Slim load monitor to be displayed or changed. Individual channel alarms can be disabled by simply clicking the alarm enable/disable box directly above the channel of interest. The occurrence of low alarms are ignored in those channels that have their low alarm monitoring disabled. To re-enable a low alarm for a particular channel, simply re-click the alarm enable/disable box that is associated with the channel of interest. Figure 6.4 details the Low SetPoint sub-function of the System SetPoints Window.

Clicking any of the boxes above a channel data box will enable or disable a low alarm setpoint on the associated channel. A check mark in the box indicates the alarm has been disabled. To enable an alarm that has been disabled, click the box again. A "clear" box indicates the alarm is

Outer Slide LOW ALARM SetPoints

<input type="checkbox"/> Total	<input type="checkbox"/> LR	<input type="checkbox"/> RR	<input type="checkbox"/> LF	<input type="checkbox"/> RF
0	0	0	0	0

Inner Slide LOW ALARM SetPoints

<input type="checkbox"/> Total	<input type="checkbox"/> LR	<input type="checkbox"/> RR	<input type="checkbox"/> LF	<input type="checkbox"/> RF
0	0	0	0	0

Capacity
High Setpoints
Low Setpoints
Benchmark
Counters

Displays the Low Alarm Setpoint values for the Total, LR, RR, LF, and RF corners of the press being monitored. Also displays if the alarm is enabled or disabled. If the online monitor has more than four channels, the Outer low alarm setpoint values are displayed. To change a low alarm setpoint value, click the data box of the channel of interest, type in the new value, then select the "Enter Key" to complete the task. Values entered into the Total data box will be equally divided amongst the other channels.

Displays the Low Alarm Setpoint values for the Inner Slide of the press being monitored. If the online load monitor has four channels or less, the alarm setpoints for the Inner slide are not visible. To change a low alarm setpoint value, click the data box of the channel of interest, type in the new value, then select the "Enter Key" to complete the task. Values entered into the Total data box will be equally divided amongst the other channels.

Clicking this button displays the online help for the Low Alarm Setpoints function of the System Setpoints Window.

Figure 6.4 - System SetPoints Window - Low Setpoints

6

SetPoints Toolbar Function - Benchmark



System SetPoints Window - Benchmark

The **Benchmark** sub-function displays or changes the percentage values that are used in conjunction with the AutoSet mode of the online Slim load monitor. Benchmark values established in AutoSet mode are also shown. The percentage values are used to establish automatic high and low alarm limits if the online Slim load monitor has been placed in AutoSet mode. The alarm limit result, is a value that is a specified percentage above and below the benchmark mark value, or the capacity value of the press. As an example, entering 20% in the High% and Low% data boxes will produce high and low alarm limits that are 20% above and 20% below the established benchmark.

If the monitor is not in AutoSet mode, the tolerance values are meaningless. For details on how to place the online load monitor into AutoSet mode, refer to the **Mode Toolbar Function**. Figure 6.5 details the Benchmark sub-function of the System SetPoints Window.

Displays or changes the percentage values used in AutoSet alarm limit calculations. If the online load monitor has four channels or less, the Benchmark values for the Inner Slide will not be visible. To change a percentage value, select the channel of interest. After the selection is made, the percentage data box for the selected channel will be highlighted.

The Tolerance DataEntry keypad will appear immediately after selecting a percentage value data box. Click a key on the Tolerance DataEntry keypad to change the percentage of the selected channel. If the selected channel is the Total, percentage values for all channels will update at the same time. After the percentage value has been chosen, click the "Send Tolerance Data to Monitor" key to download the percentages to the monitor. You may exit the Tolerance DataEntry keypad by clicking the "Exit Tolerance Data Entry" key.

Clicking this button displays the online help for the Benchmark function of the System Setpoints Window.

Figure 6.5 - System SetPoints Window - Benchmark

6 SetPoints Toolbar Function - Counters



System SetPoints Window - Counters

The **Counter** sub-function displays or changes the values associated with the stroke and batch counters of the online Slim load monitor. This window is not show in the Application Hot Key is enabled. Figure 6.6 details the Counter sub-function of the System SetPoints Window.

This value represents the lower load level that the monitor will use to validate part counts. If the load force falls below this limit, the part counting will stop until it rises above this limit. To enter a new value for the Lower Count Limit, click the associated data entry box, type in a new value, then depress the Enter key to accept the new value.

This value represents the upper load level that the monitor will use to validate part counts. If the load force exceeds this limit, the part counting will stop until it falls below this limit. To enter a new value for the Upper Count Limit, click the associated data entry box, type in a new value, then select the Enter key to accept the new value.

This value represents the batch counter and ranges from 0 to 99,999,999. Entering data into this field will activate the batch count function. When the number of parts produced matches the value in this field, the online monitor will produce a batch count alarm. If this alarm is enabled, the shutdown relay will open. Setting this value to zero will disable the batch count function. To enter a new Batch Set value, click the associated data entry box, type in a new value, then select the Enter key to accept the new value.

This value represents the stroke count of the press and is a designation of how many parts have been made. It can be reset to zero by selecting the "Clear Parts Count" button. Data cannot be entered into this field.

This value represents how many parts remain in the batch set. It is the running difference between the batch set and part count values. Setting the Batch Set data to zero disables this count.

Clicking this button displays the online help for the Counter function of the System Setpoints Window.

Figure 6.6 - System SetPoint Window - Counters

7 Details Toolbar Function

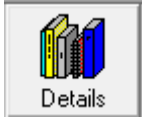

The **Details** toolbar function will enable the small Tonnage Monitor window and the System Details window as shown in Figure 7.1. The **System Details** window displays the current parameters and setup values of the online Slim load monitor. If the online Slim load monitor is in CCM mode, the active angle of the resolver is also shown. If the online Slim load monitor has four channels or less, data for the Inner Slide is not shown. The **System Details** window is password protected. See the **Data Lock** toolbar function for password entry instructions. Figure 8.2 on the following page highlights the functionality of the **System Details** window.

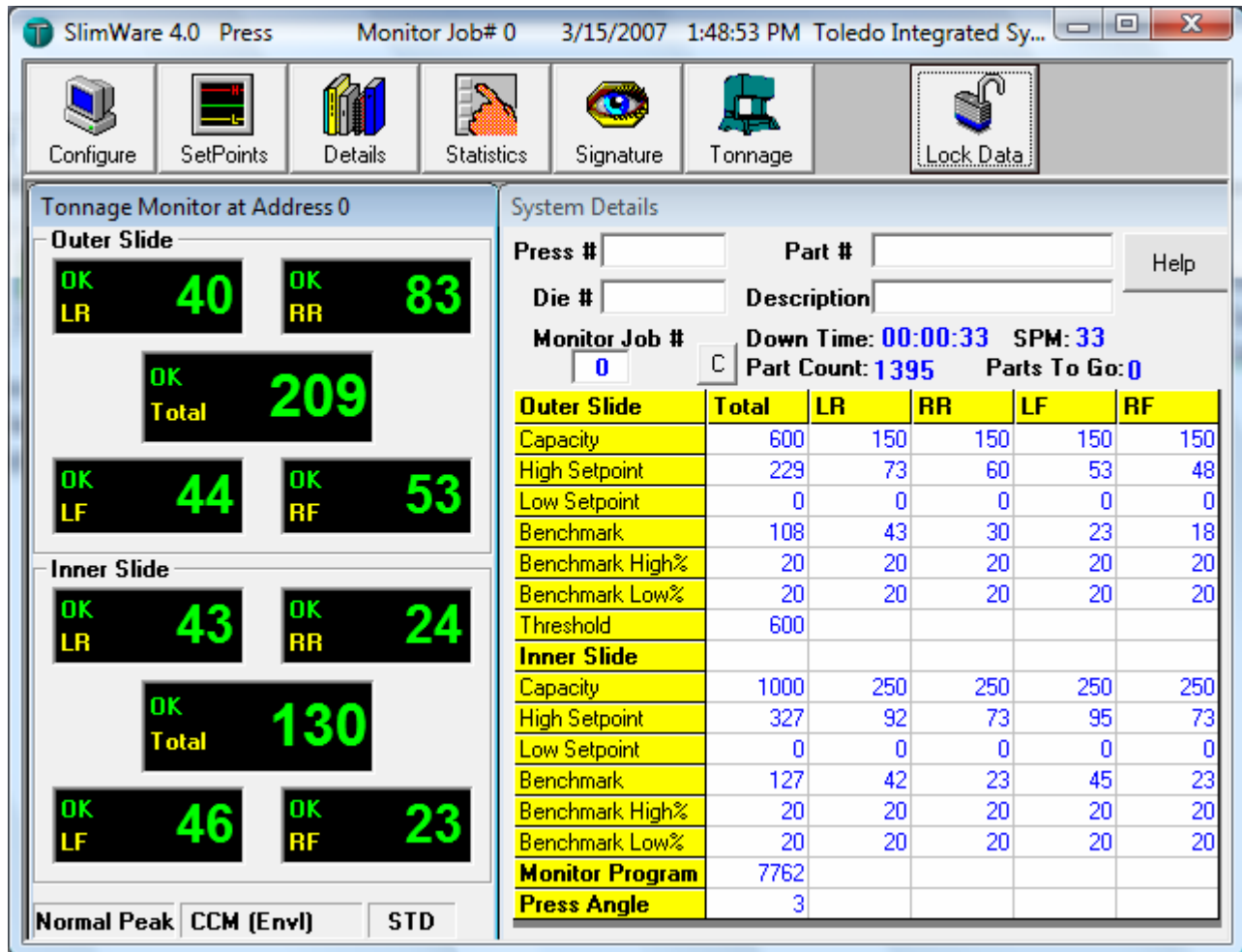
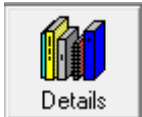

Figure 7.1 - Tonnage Monitor and System Details Windows

7 Details Toolbar Function - Continued



Press# - Displays or sets the current number of the press that SlimWare is monitoring. To enter a press number, click the associated data entry box. Type in a number (or description) up to ten characters in length. Select the Enter key when complete.

Part# - Displays or sets the current number of the part that is being produced. Type in a number (or description) up to twenty characters in length. Select the Enter key when complete.

Help - Clicking this button displays the online help for the System Details window.

Die# - Displays or sets the current number of the die that is installed in the press. Type in a number (or description) up to ten characters in length. Select the Enter key when complete.

Description - Displays or sets the current description of the part that is being produced. Type in a description up to twenty characters in length. Select the Enter key when complete.

Monitor Job# - Displays or sets the current job number of the online Slim load monitor. Changing this number will cause the Slim load monitor to retrieve operating parameters that were previously saved. To change the current Slim job number, click the associated data entry box, type in a number from 0 to 99, then select the Enter key when complete. You will then be given a choice to retrieve previously saved parameters or cancel job change.

Note: Items listed below are not displayed when the "Application Hot Key" is selected or enabled (On Configuration Page).

Down Time - Displays the time that has elapsed since a valid load has occurred. The format is days, hours, minutes. This value is reset to zero when a valid load is recognized.

SPM - Displays the operating speed of the press in strokes per minute.

Part Count - Displays the active part count. This value can be reset to zero by clicking the **C** button that is to the immediate left of the part count prompt. (Password Protected)

Parts To Go - Displays the number of parts that remain in the defined batch. If the Batch Set counter is zero, the Parts to Go count will also be zero.

System Details						
Press #	<input type="text"/>	Part #	<input type="text"/>	Help		
Die #	<input type="text"/>	Description	<input type="text"/>			
Monitor Job #	<input type="text" value="0"/>	Down Time: 00:00:40	SPM: 33			
	<input type="button" value="C"/>	Part Count: 1395	Parts To Go: 0			
Outer Slide	Total	LR	RR	LF	RF	
Capacity	600	150	150	150	150	
High Setpoint	229	73	60	53	48	
Low Setpoint	0	0	0	0	0	
Benchmark	108	43	30	23	18	
Benchmark High%	20	20	20	20	20	
Benchmark Low%	20	20	20	20	20	
Threshold	600					
Inner Slide						
Capacity	1000	250	250	250	250	
High Setpoint	327	92	73	95	73	
Low Setpoint	0	0	0	0	0	
Benchmark	127	42	23	45	23	
Benchmark High%	20	20	20	20	20	
Benchmark Low%	20	20	20	20	20	
Monitor Program	7762					
Press Angle	3					

The table data of the System Details window displays the current operating parameters of the online Slim load monitor. If the Slim load monitor is in CCM mode, the press angle data will be displayed. This data will change as the resolver angle changes. Inner slide data is not available if the online Slim load monitor has four channels or less.

Figure 7.2 - System Details Functionality

8 Statistics Toolbar Function



The **Statistics** toolbar function will enable the Tonnage Monitor window and the System Statistics window as shown in Figure 8.1. The System Statistics window displays and records load data and all high and low alarm limit violations that take place. If the online Slim load monitor has four channels or less, alarm statistics for the inner slide are not available. System Statistics can be viewed by anyone but the clear functions are only available when logged in with a supervisor/master password. See the **Data Lock** toolbar function for password entry instructions. See Figure 8.2 on the following page for **System Statistics** details.

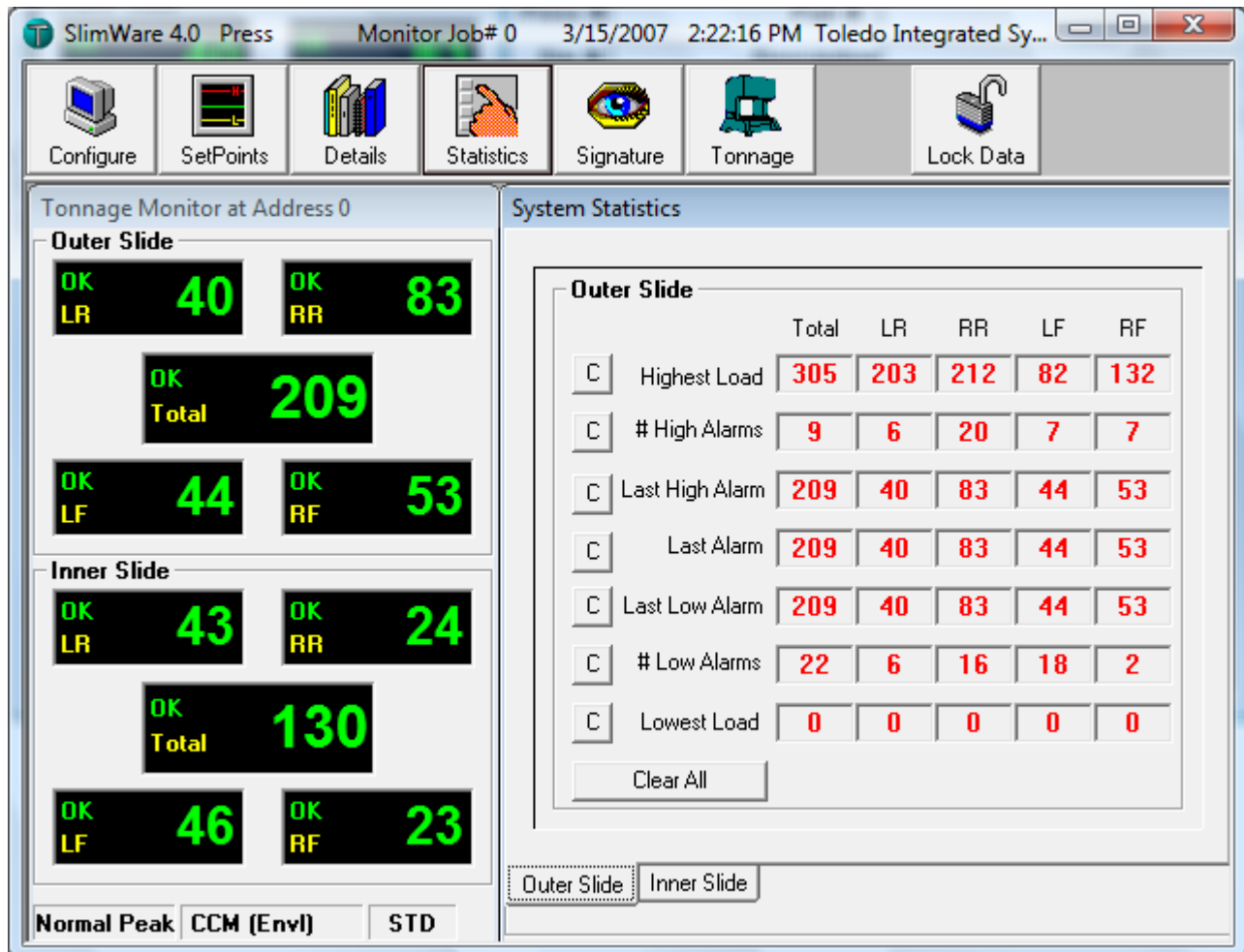

Figure 8.1 - Tonnage Monitor and System Statistics Windows

8 Statistics Toolbar Function - Continued

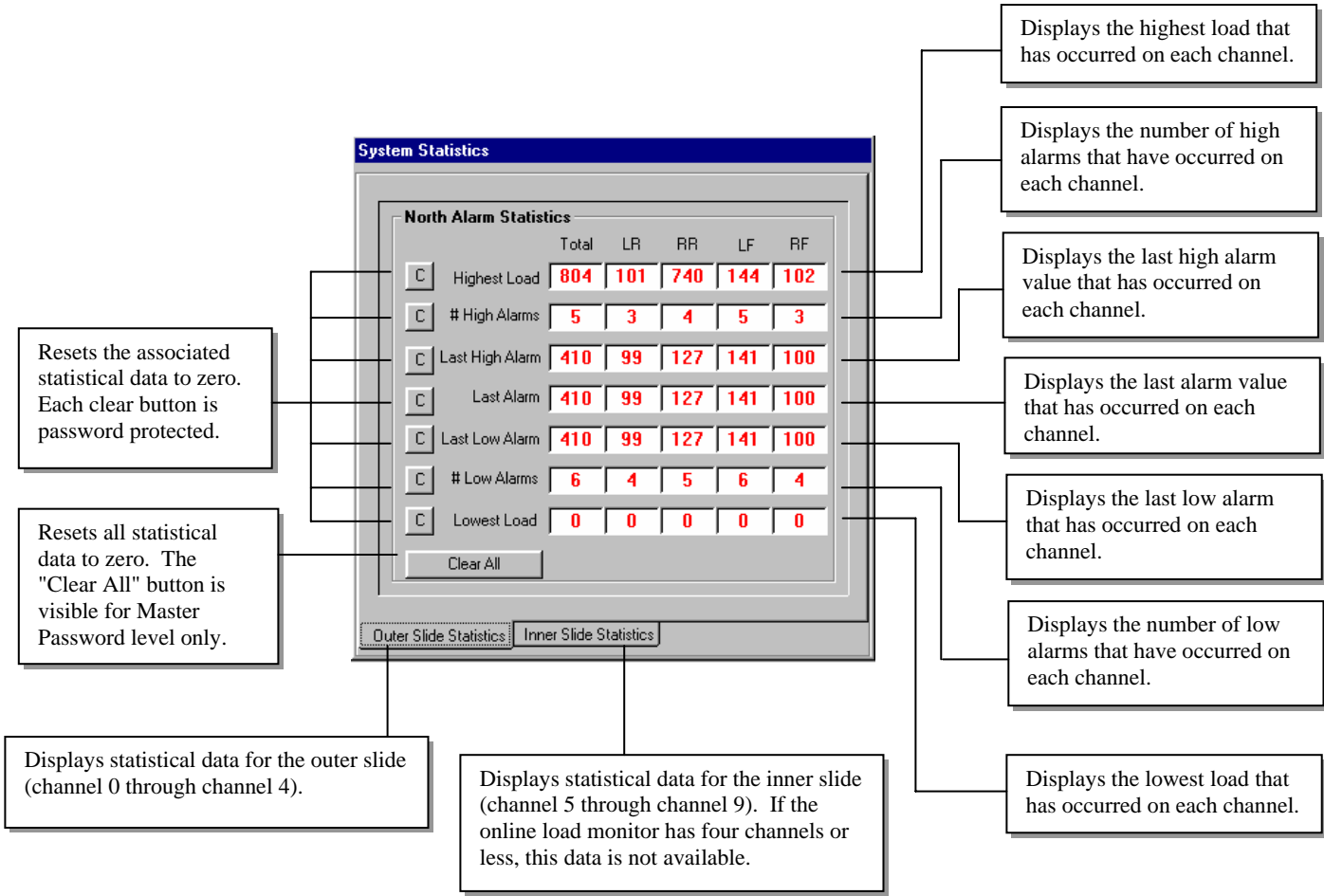

Figure 8.2 - System Statistics Details

9

Signature Toolbar Function



The **Signature** toolbar function will enable the System Process window as shown in Figure 9.1. The System Process window is used to display current or archived load signatures and enveloping. If the online load monitor is not operating with resolver triggering, the Signature Toolbar function is unavailable.

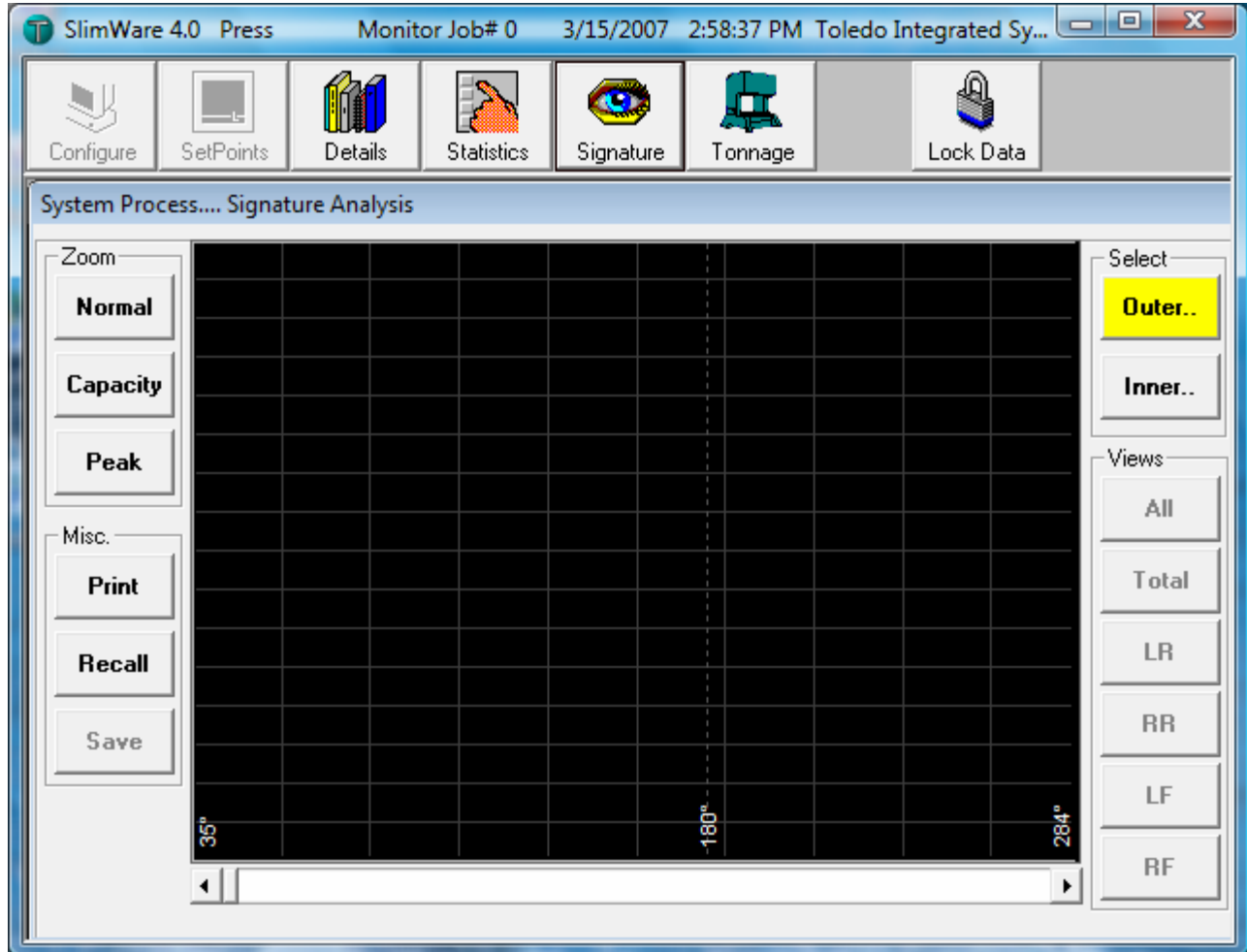

Figure 9.1 - System Process Window

9

Signature Toolbar Function - continued



System Process Window

The **System Process** window is used to view a current or archived load signature. Note: Enable Envelope Autoset must be turned on (enabled) to view enveloping with signature. Figure 9.2 details the functionality of the System Process Window. Refer to **How to Retrieve a Signature** and **How to Save a Signature** immediately following Figure 9.2.

Normal – Scales the signature to normal scale.
Capacity - Scales the signature to maximum capacity. Scale to capacity will only work if the signature selected is Total, LR, RR, LF or RF. It will not scale if the view is All.
Peak - Scales the signature to the peak tonnage. Scale to peak will only work if the signature selected is Total, LR, RR, LF or RF. It will not scale if the view is All.

Enables signature viewing of the Outer or Inner Slides of the press. A highlighted button indicates which slide has been selected. If the online monitor has four channels or less, the Select box is not visible. In this case, the default view for signatures will be channels 0 through channels 4.

System Process... Signature Analysis

Zoom

Normal

Capacity

Peak

Misc.

Print

Recall

Save

Select

Outer..

Inner..

Views

All

Total

LR

RR

LF

RF

Selecting buttons within the Views Control Bar will enable various views of the active signature to be displayed. An explanation of each button follows.

All - Displays all four corners of signature. Click the All button again to bring up signatures from each channel stacked on top of one another. Continue to select the All button to bring the signature of the channel of interest to the foreground.

Total - Enables the Total view of the active signature.

LR - Enables the Left Rear view of the active signature.

RR - Enables the Right Rear view of the active signature.

LF - Enables the Left Front view of the active signature.

RF - Enables the Right Front view of the active signature.

Save - Signatures which are currently displayed can be saved to a file by selecting this button. The **Save** button only becomes active if a signature has been recalled.

Recall - Recalls a signature from the online monitor, or from an archived file.

Print – Prints the the signature window.

Recall - Recalls a signature from the online monitor, or from an archived file.

Save - Signatures which are currently displayed can be saved to a file by selecting this button. The **Save** button only becomes active if a signature has been recalled.

The signature data bar allows information of the displayed signature to be viewed in table format. Signature data begins at 35 degrees and ends at 284 degrees. Moving the data bar slide button to the right increments the degree pointer value. Moving the data bar slide button to the left, decrements the degree pointer value. Selecting the left and right arrows of the signature data box, accomplishes the same task as the slide button. The signature data table may also be displayed by clicking any point on the signature that is being viewed.

Figure 9.2 - System Process Functionality

9

Signature Toolbar Function - continued



How to Retrieve a Signature

Signature Retrieval from an online Slim load monitor

- Select the **Recall** button on the System Process window. The **Recall Signature** prompt box will be displayed as shown in Figure 9.3. Click the button **From Monitor** to begin downloading a signature from the online Slim load monitor.

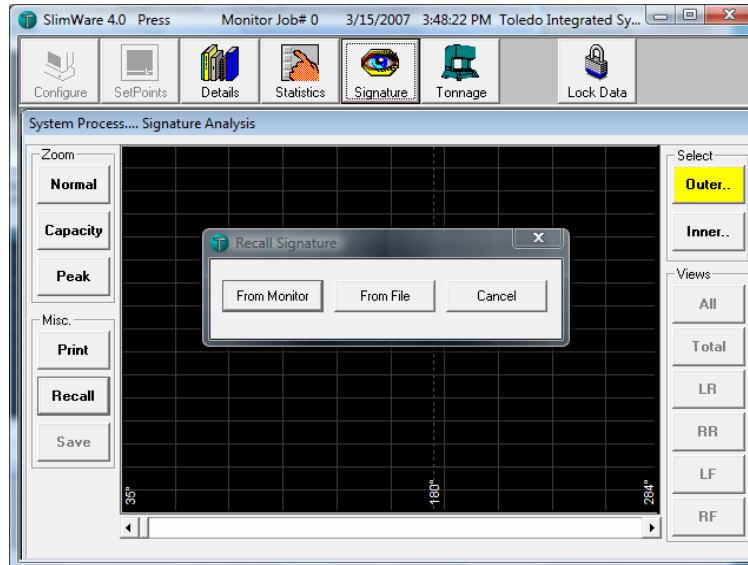

Figure 9.3 - Recall Signature Prompt Box (Select From Monitor)

- The **Signature DownLoad in Progress** prompt box will appear, showing the active progress of the signature data download (refer to Figure 9.4).

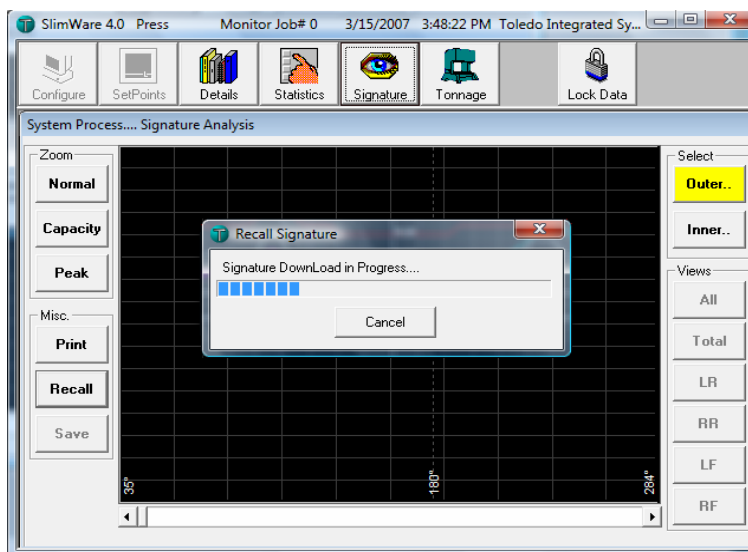

Figure 9.4 - Signature DownLoad in Progress Prompt Box

9

Signature Toolbar Function - continued

How to Retrieve a Signature - continued**Signature Retrieval from an online Slim load monitor**

- After the signature download completes, the progress prompt box will close and the retrieved signature will be displayed (refer to Figure 9.5). You may now look at other views of the signature by selecting a button within the Select and Views control bars. If the online Slim load monitor has four channels or less, the Select control bar is not visible.

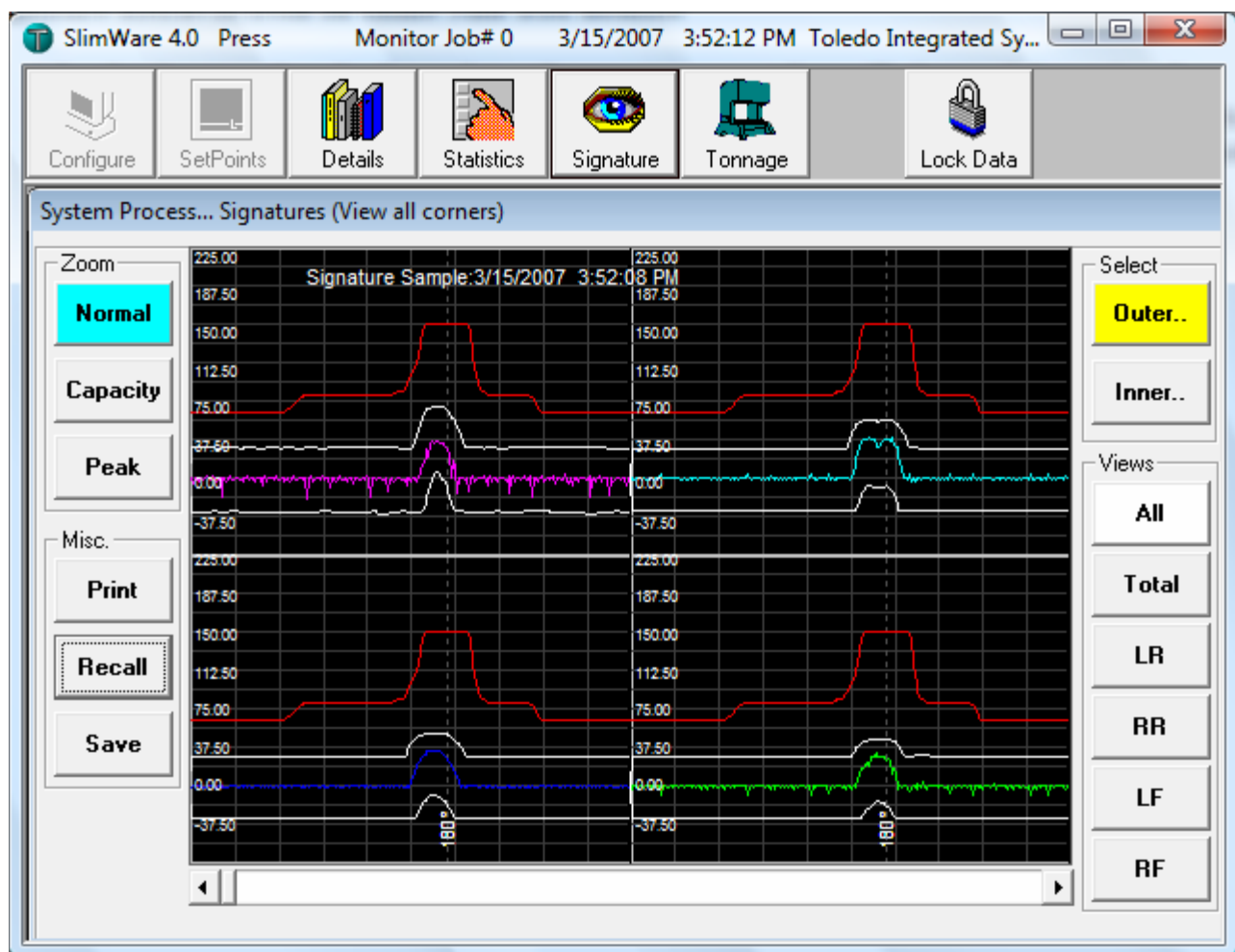

Figure 9.5 - Downloaded Signature From Online Load Monitor

9

Signature Toolbar Function - continued

How to Retrieve a Signature - continued**Signature Retrieval from an Archived File**

- Select the Recall button on the System Process window. The **Recall Signature** prompt box will be displayed as shown in Figure 9.6. Click the button **From File**.

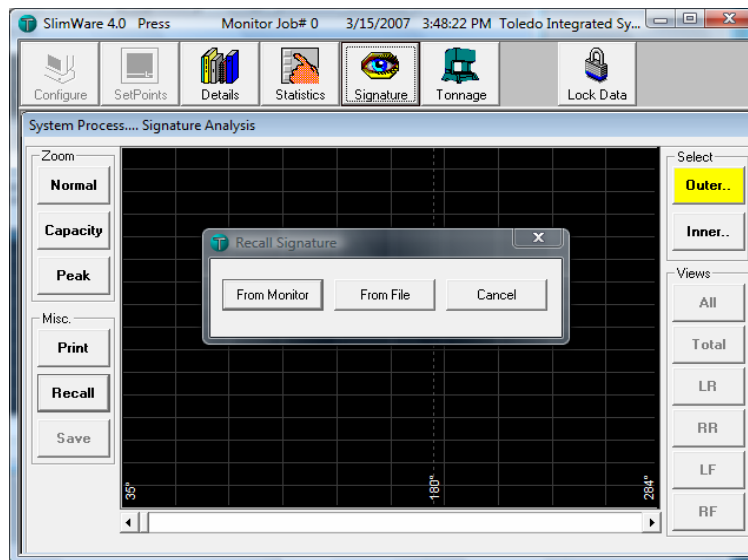

Figure 9.6 - Recall Signature Prompt Box (Select From File)

- The **Recall Signature From File** prompt box will be displayed as shown in Figure 9.7. Signatures that were produced and saved using SlimWare, will have the extension **sws** (SlimWare Signature). Select the signature file you wish to open from the **Select File** list box.

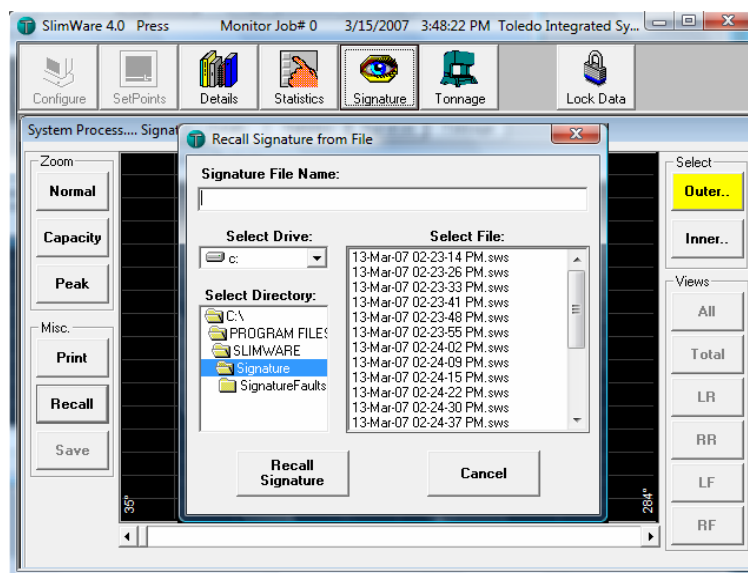

Figure 9.7 - Recall Signature From File Prompt Box

9

Signature Toolbar Function - continued

How to Retrieve a Signature - continued**Signature Retrieval from an Archived File**

- After the signature has been retrieved from the file, the file box will close and the requested signature will be displayed (refer to Figure 9.8). You may now look at other views of the signature by selecting a button within the Select and Views control bars.

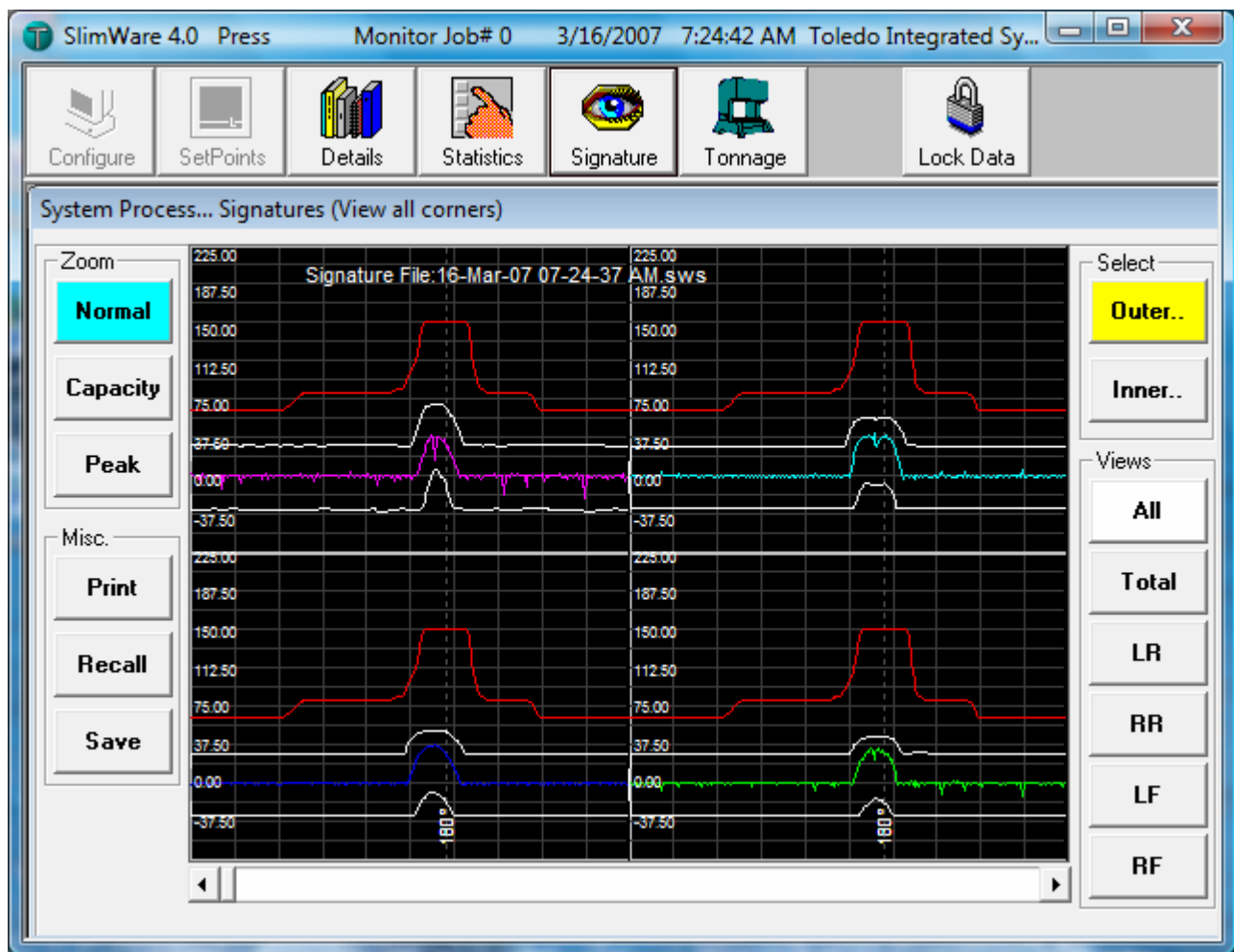

Figure 9.8 - Signature Retrieved From File

9

Signature Toolbar Function - continued



How to Save a Signature - continued

- Download a signature from the online Slim load monitor. When the download is complete, select the **Save** button on the System Process window. The **Save Signature to File** prompt box will be displayed as shown in Figure 9.9.

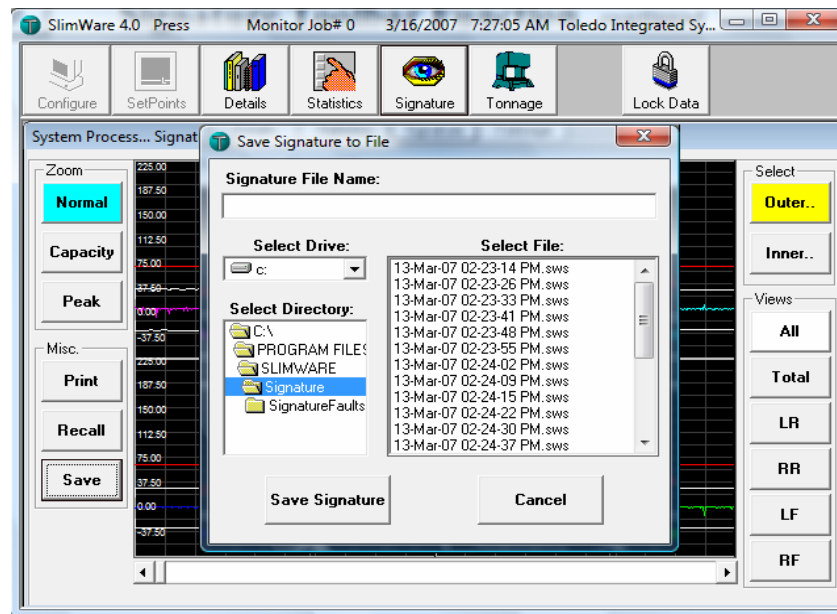

Figure 9.9 - Save Signature to File Prompt Box

- Click the **Signature File Name** data entry box. Type in a file name that will describe the signature you want to save. You may use up to thirty-two characters. If the signature already exist, simply click the name of the file in the **Select File** list box.
- Click the **Save Signature** button to save the signature to the file. If the signature file already exist, you will be prompted and given a choice to overwrite the file.

Automatic Signature Retrieval

By enabling the **Automatic Retrieval** option under the SLIM Software tab in the configuration page, signatures are saved after a designated number of strokes (also declared on the configuration page). These signatures are saved in the “Signatures” folder under C:\Program Files\SlimWare\Signatures”.

If the **Automatic Retrieval** option is checked, signatures saved to this folder will be deleted if they 3 days or older. This includes saving a file manually (as above) or automatically.

By using the **Automatic Retrieval** option, files are saved with the date and time the signature was taken.

10

Tonnage Toolbar Function



The **Tonnage** toolbar function will enable the Tonnage Monitor window as shown in Figure 10.1. The Tonnage Monitor window displays the current tonnage along with the alarm status of each channel. Also displayed are the bar graphs displaying the current tonnage, high and low setpoints and capacity of each corner. This is used primarily as a graphical representation to quickly compare tonnage/setpoints on each corner.

If the online Slim load monitor has four channels or less, the four channel displays are expanded to show a greater viewing area. The Tonnage Monitor window is not password protected and can be viewed by anyone. Certain features such as putting the monitor into setup/learn modes are password protected and can only be accessed with a setup password or higher. See the **Data Lock** toolbar function for password entry instructions.

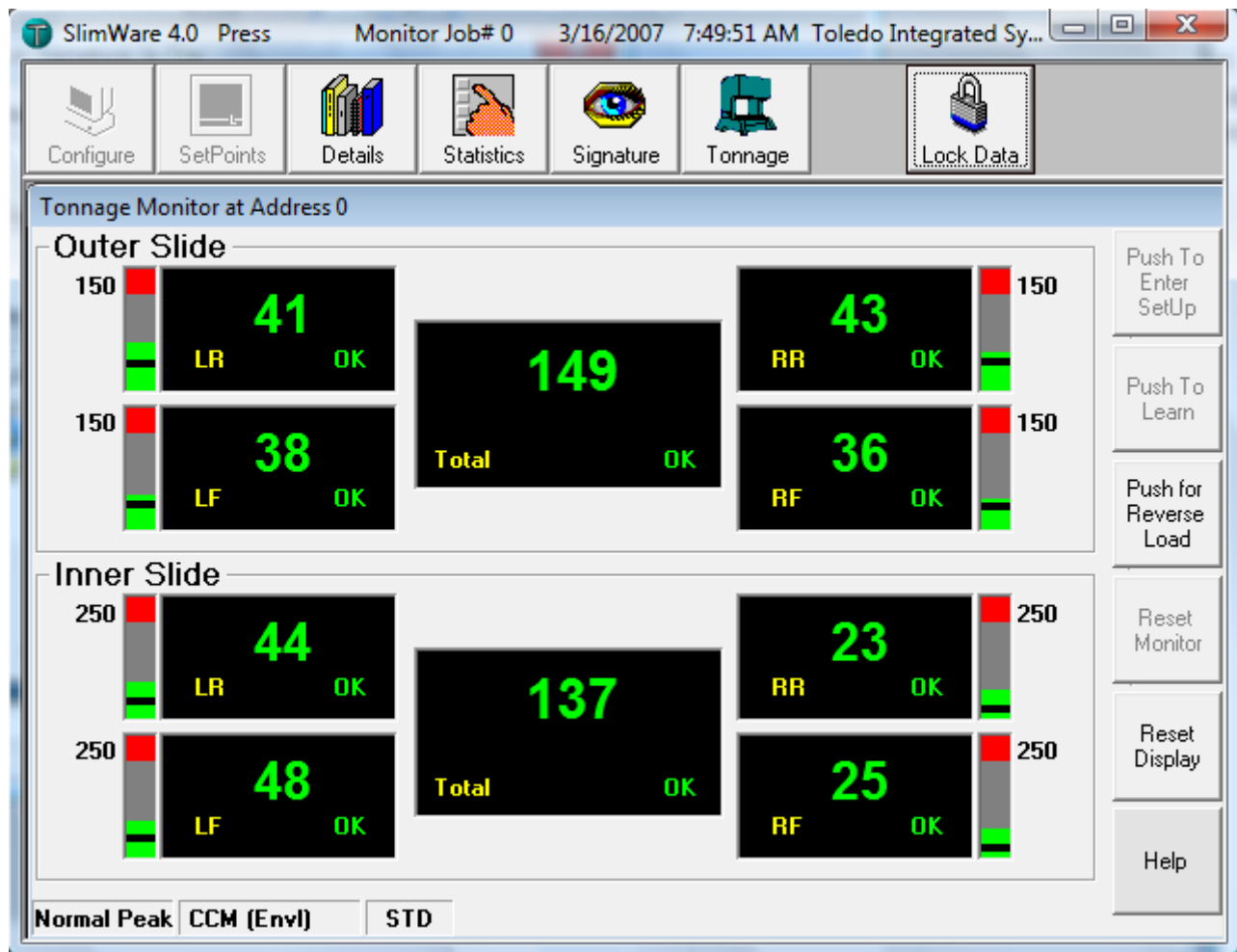

Figure 10.1 - Tonnage Monitor Window

10

Tonnage Toolbar Function - continued



The **Tonnage** Monitor window displays the current tonnage, alarm status of each channel and also buttons which are used to control the operation of the online Slim load monitor. Figures 10.2 and 10.3 show in detail the function of each display and button.

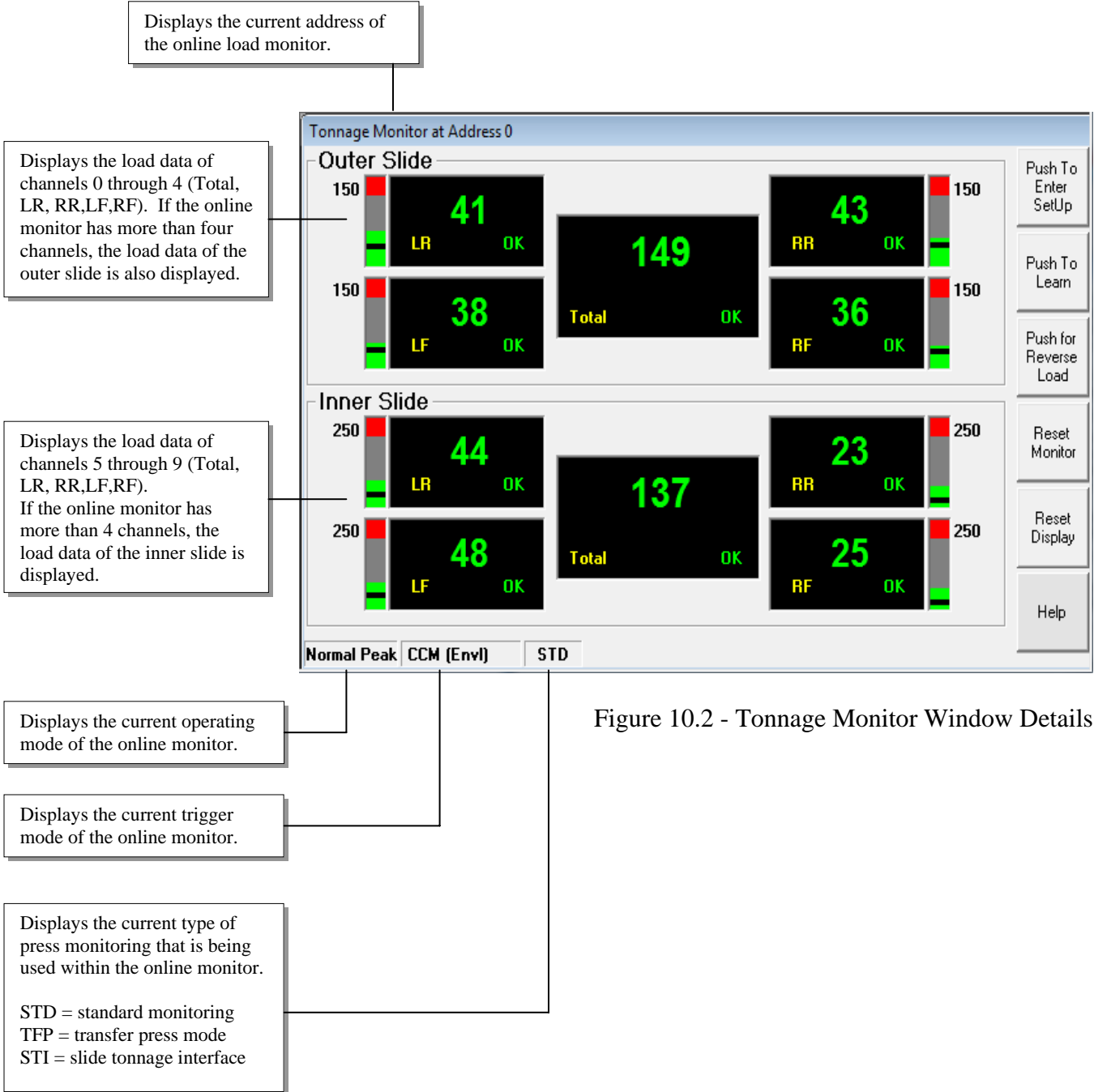

Figure 10.2 - Tonnage Monitor Window Details



10

Tonnage Toolbar Function - continued



Clicking this button will place the online monitor into Setup mode. When Setup mode is active, only Capacity alarms are active on the online monitor. (Password Protected)



Clicking this button will place the online monitor into Learn mode. When Learn mode is active, a benchmark is established after eight cycles. If AutoSet is active, high and low limits will automatically be established based upon the benchmark value. (Password Protected)

Clicking this button will display the reverse load value.

Clicking this button will reset any pending alarms. (Password Protected)

Clicking this button will reset the display to all zeros.

Clicking this button displays the online help information for the Tonnage Monitor window.

Figure 10.3 - Tonnage Monitor Window Details

11**Virtual KeyPad**

The virtual keypad has been developed specifically for touch screen applications that do not have an attached keyboard. However, the virtual keypad can be used with a mouse. Any parameter within SlimWare that can be changed, will automatically call the virtual keypad when the parameter's associated data entry box is clicked or touched. To enable the virtual keypad, click the **Virtual KeyPad Option** on the second page of the Configuration window. A check mark in the option selection box indicates the **Virtual KeyPad** function is active. To disable the function, simply click the **Virtual KeyPad Option** button again. Figure 11.1 shows the numeric keypad while figure 11.2 shows the alphanumeric keypad. Both keypads will display automatically, dependent upon the type of parameter being changed within SlimWare. To clear a data entry, click the clear key of the respective keypad. To close the virtual keypad after use, click the close box (x) in the upper right corner of the title bar.

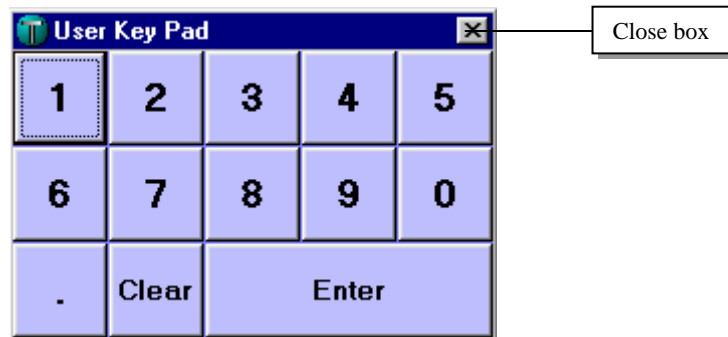

Figure 11.1 - Numeric Virtual Keypad

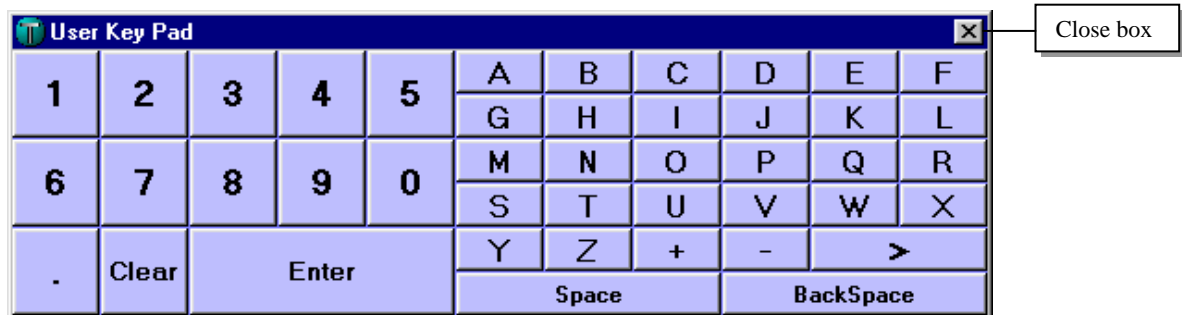

Figure 11.2 - Alphanumeric Virtual Keypad

12

Lock Data ToolBar Function



The **Lock Data** toolbar function controls the locking and unlocking of SlimWare parameters that can be changed. The **Lock Data** function requires a User ID and a valid password before SlimWare operating parameters can be altered. SlimWare functions that have locked parameters will have the **Data Locked** prompt displayed as shown in Figure 12.1. If this prompt is visible, operating parameters cannot be altered. You must unlock the data to gain access.

DATA LOCKED

Figure 12.1 - Data Locked prompt

To gain access to locked operating parameters, select the **Lock Data** button from the main toolbar. The password entry box will display as shown in Figure 12.2. If the **KeyPad** function has been enabled, the virtual keypad will also display. To unlock operating parameters, three levels of password protection are available. The first level is for Supervisory/Master access. The second level is for Setup access. The third level is for Operator access. Select the **Master** User ID option then click the password data entry box and type in the phrase **MASTER** to enable first level access. **MASTER** is the default Supervisor/Master password. To gain second level access, select the **Setup** User ID option then click the password data entry box and type in the phrase **SETUP**. **SETUP** is the default Setup password. To gain third level access, select the **Operator** User ID option (default) then click the password data entry box and type in the phrase **OPERATOR**. **OPERATOR** is the default Operator password. **When entering passwords that contain text, always use capital letters. When the PassWord Entry box displays, the keyboard CAPS function will enable automatically.** Select **OK** to accept the password entry. If the password is validated correctly, the **Data Lock** icon will unlock as shown in Figure 12.3.

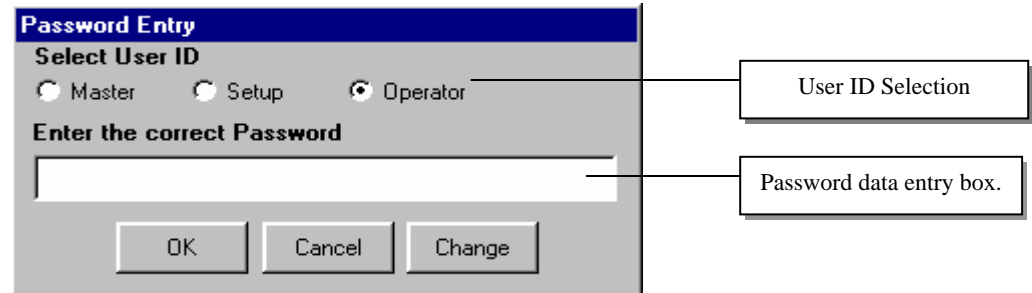

Figure 12.2 - Password Entry Box



Setup/Operator/Master Access

Figure 12.3 - Lock Data icon in Unlocked State

Once the **Lock Data** function becomes unlocked, you will have eight minutes to change operating parameters. When seven minutes have elapsed, the **Lock Data** button will begin to flash Red. This is an indication that the operating parameters will lock automatically in one minute. You must complete your operating parameter changes before this time expires. After the eight minutes have elapsed, the **Lock Data** function will lock all operating parameters from being changed. To regain access to the operating parameters, you must unlock and re-enter the password. The default password can be changed if desired. To change the default password, see the following pages.

12

Lock Data ToolBar Function - continued

**How to change the active Password.**

When SlimWare is started for the very first time, the user password will default to the phrase **MASTER, SETUP OR OPERATOR**. These passwords can be changed if necessary by performing the following steps.

- Click the **Lock Data** button on the main toolbar in order to display the password entry box. (Refer to Figure 12.4)

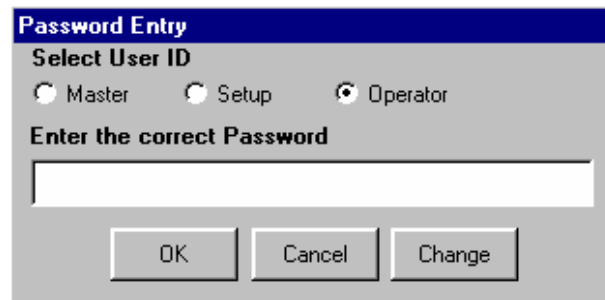

Figure 12.4 - Password Entry Box – How to Change the Active Password

- Click the **Change** button. The **Change User PassWord** box will display as shown in Figure 12.5



Figure 12.5 - Change User Password Box

- Select a User ID: Master, Setup or Operator
- Click the **current User Password** data entry box. Type in the current password. If the default password has not been previously changed, enter the phrase **MASTER, SETUP or OPERATOR**. Remember to use capital letters when entering text for the password.
- Click the **Enter the New User Password** data entry box. Type in the new password, using any combination of numbers and letters. Letter must be entered in upper case only. Characters other than A through Z and 0 through 9 are not valid. When complete, select the **OK** button. The **New PassWord** prompt box will display as shown in Figure 12.6. Select the **OK** button on the prompt box. The new password is now in effect.



Figure 12.6 - New PassWord Prompt Box

13

Application Hot Key Function



Selecting the **Application** hot key, will bring the designated application to the foreground if the application is loaded and active. The designated application must be running in order for this hot key to work. If the designated application is not running and a request is made to bring it to the foreground, the following error message will be displayed as shown in Figure 13.1. See section 5 on details regarding this function.

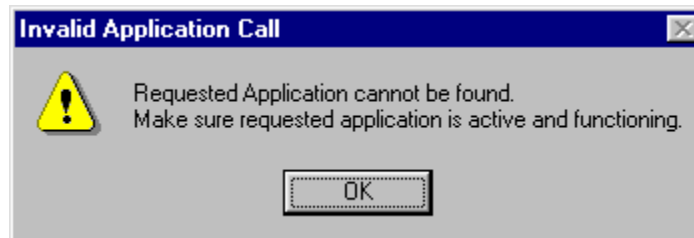

Figure 13.1 - Invalid Application Call Prompt Box

In a multiple application system, SlimWare can be brought to the foreground by using the identification name of **SlimWare** in the calling application's hot key routine.

14

SlimWare's Alarm Indications

Each time that an alarm condition occurs within the online Slim load monitor, the alarm information is retrieved and processed. The information that is processed determines the type of alarm issued and the channel that caused the alarm. SlimWare produces an alarm indication in response to any type of alarm that occurs within the online Slim load monitor. The alarm condition will remain in effect until it is reset by the user. If the online Slim load monitor is in CCM Mode, the signature that was associated with the alarm condition will automatically be saved and displayed in the signature window. Simply drag the alarm indication box to one side to view the alarming signature. To reset the alarm condition of the online Slim load monitor, select the Alarm Reset button in the Alarm Active prompt box. Figure 14.1 details the alarm indications of SlimWare.

The Active Alarm box will display each time an alarm condition occurs within the online load monitor. The type of alarm is referenced in the alarm type box. Valid alarms for this box are Channel Alarm and Part Count Alarm. To reset the active alarm, select the Alarm Reset button.

Red dot indicates one or more alarms have been bypassed.

When an alarm condition exist, the channel(s) that caused the alarm, will be highlighted in Red indicating the alarm value and the type of alarm that occurred. Valid alarms are High, Low, and CCM.

The screenshot shows the SlimWare 4.0 interface. At the top, there's a menu bar with icons for Configure, SetPoints, Details, Statistics, Signature, Tonnage, and Lock Data. Below that, the main display area is titled 'Tonnage Monitor at Address 0'. It is divided into 'Outer Slide' and 'Inner Slide' sections. Each section contains several channels with their current values and status indicators (e.g., 'LR OK', 'LF HIGH', 'RR HIGH', 'RF OK'). A 'SlimWare Active Alarm' dialog box is prominently displayed in the center, showing 'ALARM Channel Capacity Alarm' and an 'Alarm Reset' button. A red dot is visible above the dialog box, indicating a bypassed alarm. On the right side, there are several control buttons: 'Push To Enter SetUp', 'Push To Learn', 'Push for Reverse Load', 'Reset Monitor', 'Reset Display', and 'Help'. At the bottom, there are status indicators for 'Normal Peak', 'Alarm', and 'STD'.

Figure 14.1 - SlimWare's Alarm Indications

15***Resolver Error Box***

If the resolver cable or connection becomes disconnected the following error message will be displayed as shown in Figure 15.1.

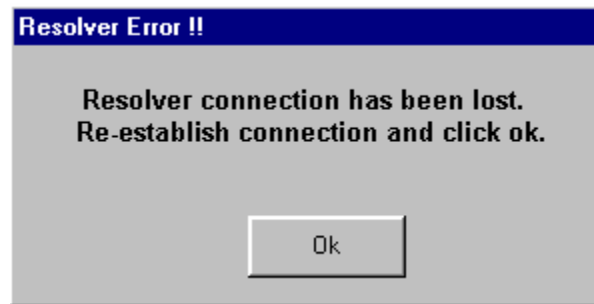

Figure 15.1 - Resolver Error Prompt Box

You must restore the resolver connection and then select the "Ok" button to clear the resolver error message box. There has been a 3 second delay added to this message box to give an operator time to switch modes from resolver to trigger or probe.