

MoniTtor™ N269 AUTOMATIC PRESS LOAD MONITORING METER

For Refractory/
Compaction Presses

The MoniTtor™ N269 load meter provides the most advanced information and control available today for your refractory or compaction press. . . far more comprehensive and complete than a typical tonnage meter. Your press can work more efficiently today and be ready for tomorrow. It gives you the control and information communications capability needed now, and becomes a basic part of your expansion to a Computer Integrated Manufacturing (CIM) system.

MoniTtor™ provides the means on an individual press to:

- Improve product quality, reduce scrap, increase profits.
- Determine the load of each press cycle. Protect against overload.
- Automatically operate "increase fill" or "decrease fill" relays.
- Measure press performance against your established standards. You set acceptable range of compaction force.
- Solve quality control and size variable problems.
- Continuously check on job status. . . forecast completion.

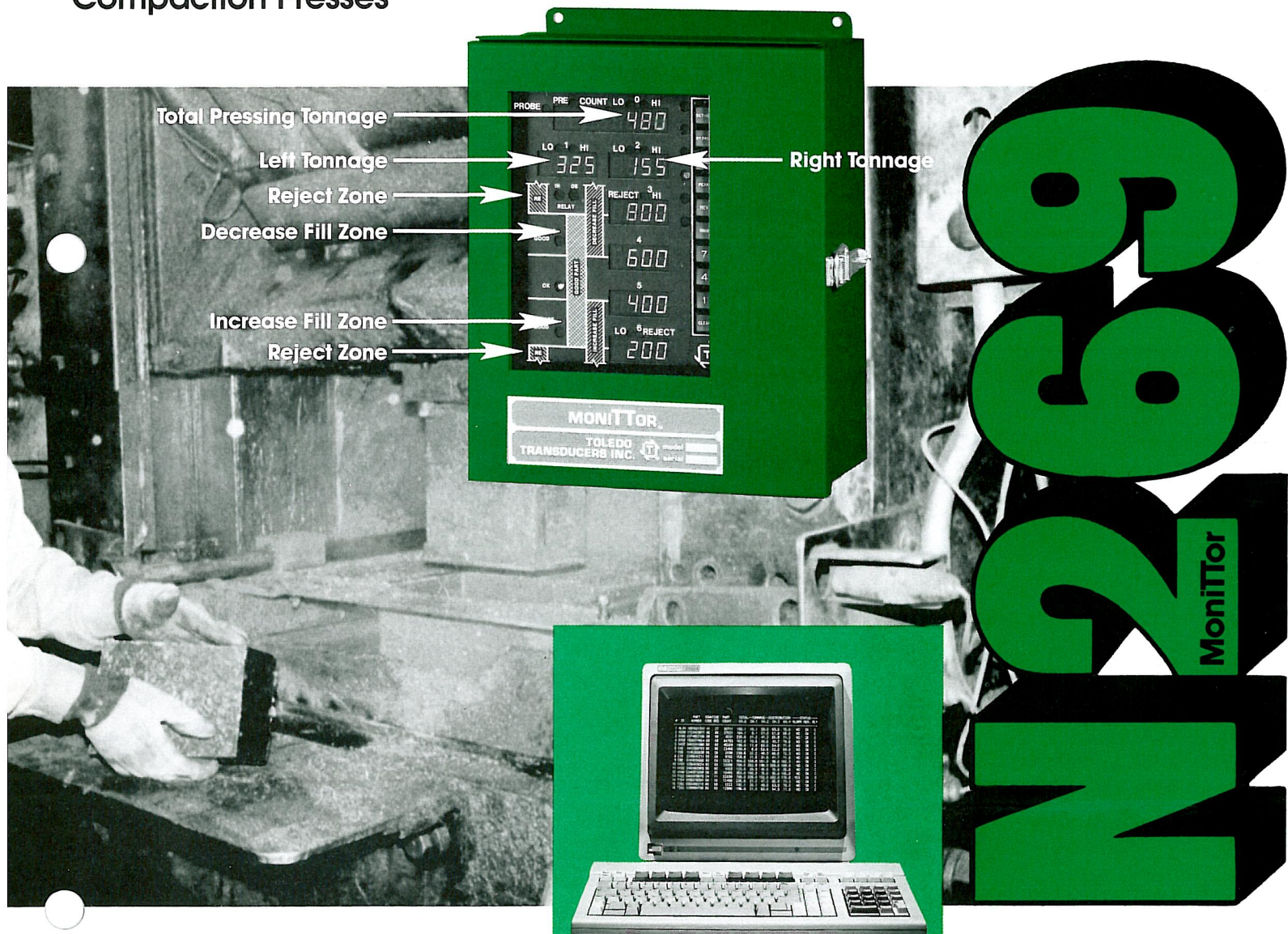

TOLEDO TRANSDUCERS, INC. Electronic Monitors & Sensors "MAKES DOLLARS AND SENSE"

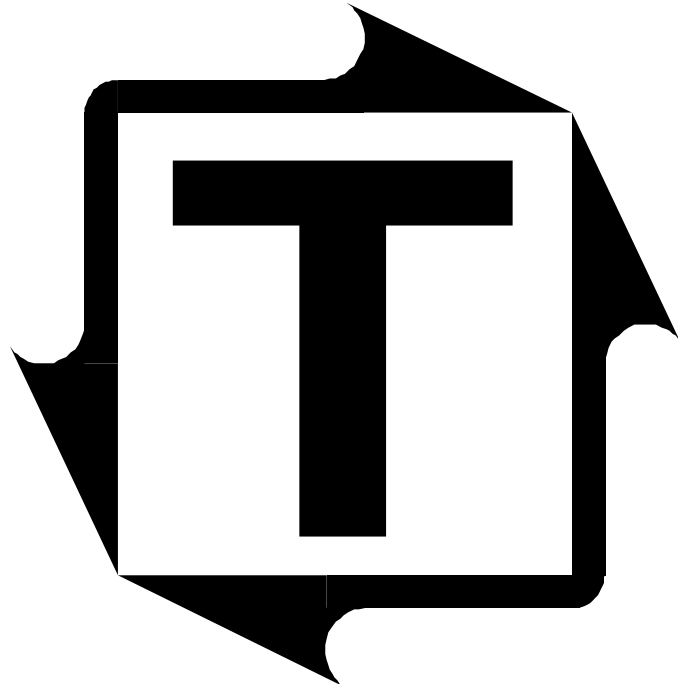

N269
Installation and
Operations Manual



Scan to visit us
on the web

**THIS PAGE
INTENTIONALLY
LEFT BLANK**

N269 Manual

Table of Contents

I.D. Page	
Warranty	Page 1
Figure 1 - Enclosure Mounting Dimensions	Page 2
Figure 2 - AC Power Hookup	Page 4
Figure 3 - Sensor Hookup	Page 5
Figure 4 - Main PC Computer Interface Wiring and Settings	Page 6
Figure 5 - N269 Front Panel	Page 7
Figure 6 - Keyboard Jumpers and Switches	Page 8
Figure 7 - N269 Process Control Zone Chart	Page 9
N269 Operators Guide	Page 10
I. General Description	Page 12
II. Operation	Page 14
A. Using The Display and Keyboard.....	Page 14
1. Load Display	Page 14
2. Data Display	Page 14
3. Data Entry Display	Page 14
4. Key Sequences	Page 15
B. Using The Process Control Features.....	Page 15
1. The Setpoints and Zones	Page 15
2. The Relays	Page 16
a. Setting the Relay Timers	Page 17
b. Setting the Relay Preset Counters	Page 17
C. Other Setpoints.....	Page 17
1. High Setpoints	Page 17
2. Low Setpoints	Page 18
3. Resetting Alarms	Page 19
D. Counters.....	Page 20
1. The Stroke Counter	Page 20
2. The Batch Counter	Page 20
3. The Process Control Counters	Page 20
4. The Alarm Counters	Page 21
a. High Counters	Page 21
b. Low Counters	Page 22
E. Additional Operating Modes.....	Page 22
1. Set-up Mode	Page 22
2. Time Mode	Page 22
a. Description	Page 22
b. Setting the Time Value	Page 23
c. The Point-In-Time Load	Page 23
d. The First Level Load	Page 24
e. The Second Level Load	Page 24
f. The B4 Mode	Page 25
3. Average Loads	Page 25
4. Reverse Mode	Page 26
F. Other Settings.....	Page 26
1. The Stroke Counter Setpoints	Page 26
2. Clearing the N269 Memory	Page 27

G. Other Information.....	Page 27
1. The Last Alarm	Page 27
2. The Last High Alarm	Page 27
3. The Last Low Alarm	Page 28
4. The Highest Load	Page 28
5. The Lowest Load	Page 28
6. The Production Rate in Strokes per Minute	Page 28
7. The Down-time (Time since the Last Stroke)	Page 29
8. The Diagnostics	Page 29
III. Installation	Page 30
A. Mounting the Enclosure.....	Page 30
B. AC & Power Connections.....	Page 30
C. Sensor Hookup.....	Page 31
D. Powering the Meter up.....	Page 31
E. Initial settings.....	Page 32
1. Decimal Point Location	Page 32
2. Press Capacity	Page 32
3. Triggering the Meter	Page 33
a. The Threshold	Page 33
b. The Probe Input	Page 33
4. The Maximum Channel Number	Page 33
5. Track (calibration) Mode	Page 34
6. The Calibration Shunt	Page 34
7. Peak Mode	Page 34
F. Calibration.....	Page 35
1. Pre-calibrated Load Cells	Page 35
2. Calculated Calibrations	Page 36
3. Calibration using Reference Load Cells	Page 36
G. Computer Interface Hookup.....	Page 37
1. RS422 Interfaces	Page 37
2. RS232 Interfaces	Page 37
3. Setup Parameters	Page 37
IV. Troubleshooting Information	Page 39
A. Using the Output Jack.....	Page 39
B. Symptoms and Solutions.....	Page 39
V. Serial Communications Protocol	Page 40
A. The Hardware Connection.....	Page 40
B. Transmission Characteristics.....	Page 40
C. Record Construction.....	Page 40
1. The Header	Page 40
2. The Trailer	Page 40
3. Data - Computer generated	Page 40
a. Data Type Character	Page 40
b. Command Character	Page 41
c. Entry Data	Page 41
d. Data Type Characters	Page 41
4. Data - N269 Generated	Page 44
a. Record	Page 44
b. Mode Construction	Page 44
c. High and Low LED Construction	Page 45
d. LED Conventions	Page 45
e. Numbers	Page 46
f. Checksum Calculation	Page 46

INSTRUMENT IDENTIFICATION

Name AUTOMATIC PROCESS CONTROL LOAD MONITOR

Model No. N269

Serial No. _____

Date Shipped _____

Company: _____
(name)

(street address)

(city - state - zip)

(telephone number)

Purchase Order No. _____

Invoice No. _____

LIMITED WARRANTY

This unit is warranted by the manufacturer, Toledo Transducers, Inc., to be free of defects in workmanship and material for one year from date of manufacturer's shipment. This warranty is limited to repairing or replacing products which manufacturer's investigation shows were defective at the time of shipment by the manufacturer. All products subject to this warranty must be returned F.O.B., Toledo Transducers, Inc., 6834 Spring Valley Drive, Holland, Ohio 43528, for examination, repair, or replacement.

THE EXPRESS WARRANTY SET FORTH HEREIN IS IN LIEU OF ALL OTHER WARRANTIES, EXPRESS OR IMPLIED, INCLUDING WITHOUT LIMITATION ANY WARRANTIES OF MERCHANT-ABILITY OR FITNESS FOR A PARTICULAR PURPOSE. ALL SUCH WARRANTIES ARE HEREBY DISCLAIMED AND EXCLUDED BY THE MANUFACTURER.

Repair or replacement of defective products as provided above, is the sole and exclusive remedy provided thereunder. The manufacturer shall not be liable for any further loss, damages, or expenses, including incidental or consequential damages, directly or indirectly arising from the sale or use of this product.

This warranty is subject to installation and operating conditions described in the accompanying manual.

Any unauthorized repair voids this warranty.

There are no warranties that extend beyond those expressly set forth herein.

N260C FLUSHMOUNT MOUNTING DIMENSIONS

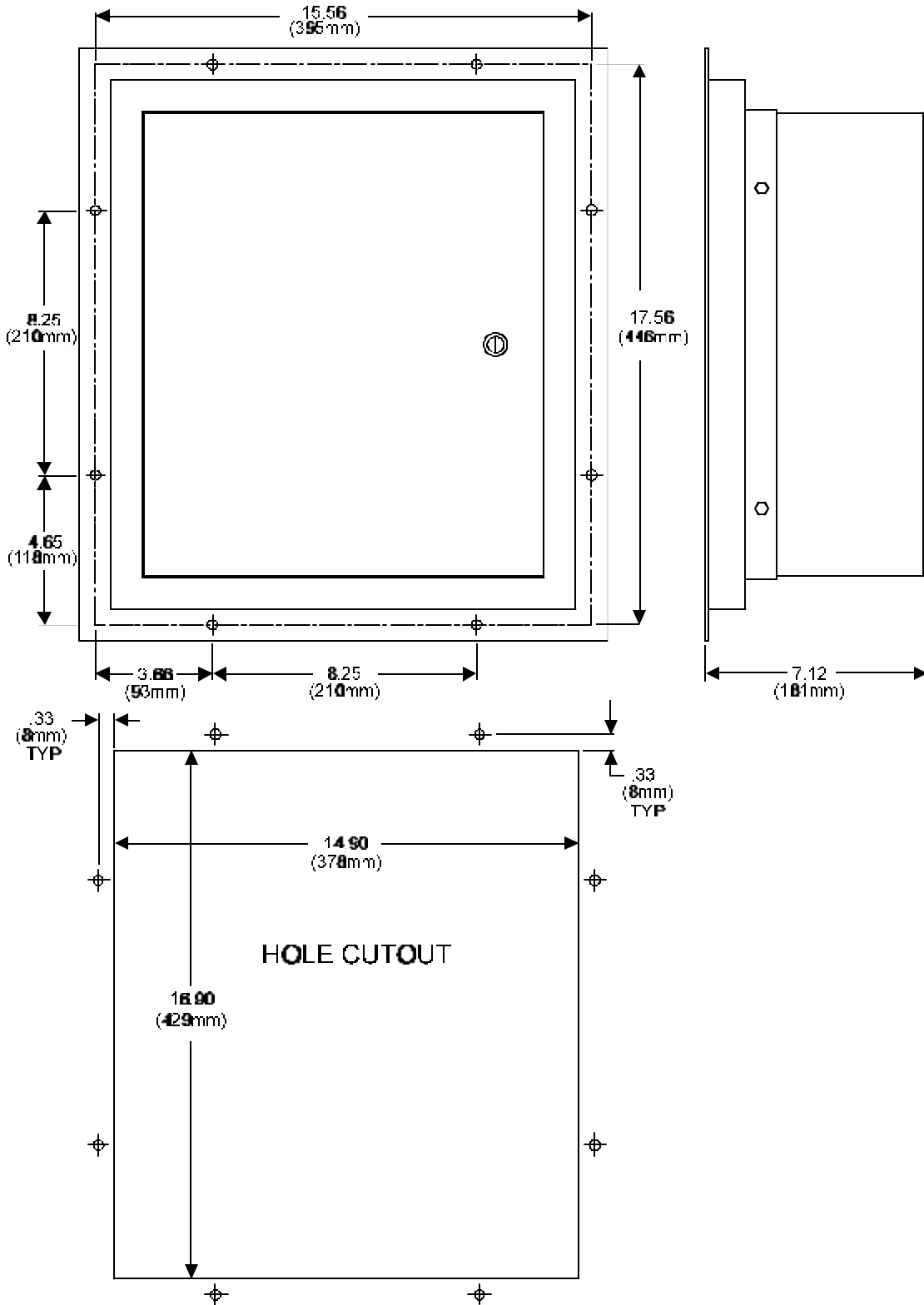

FIGURE 1

CONVERTIBLE ENCLOSURE MOUNTING DIMENSIONS

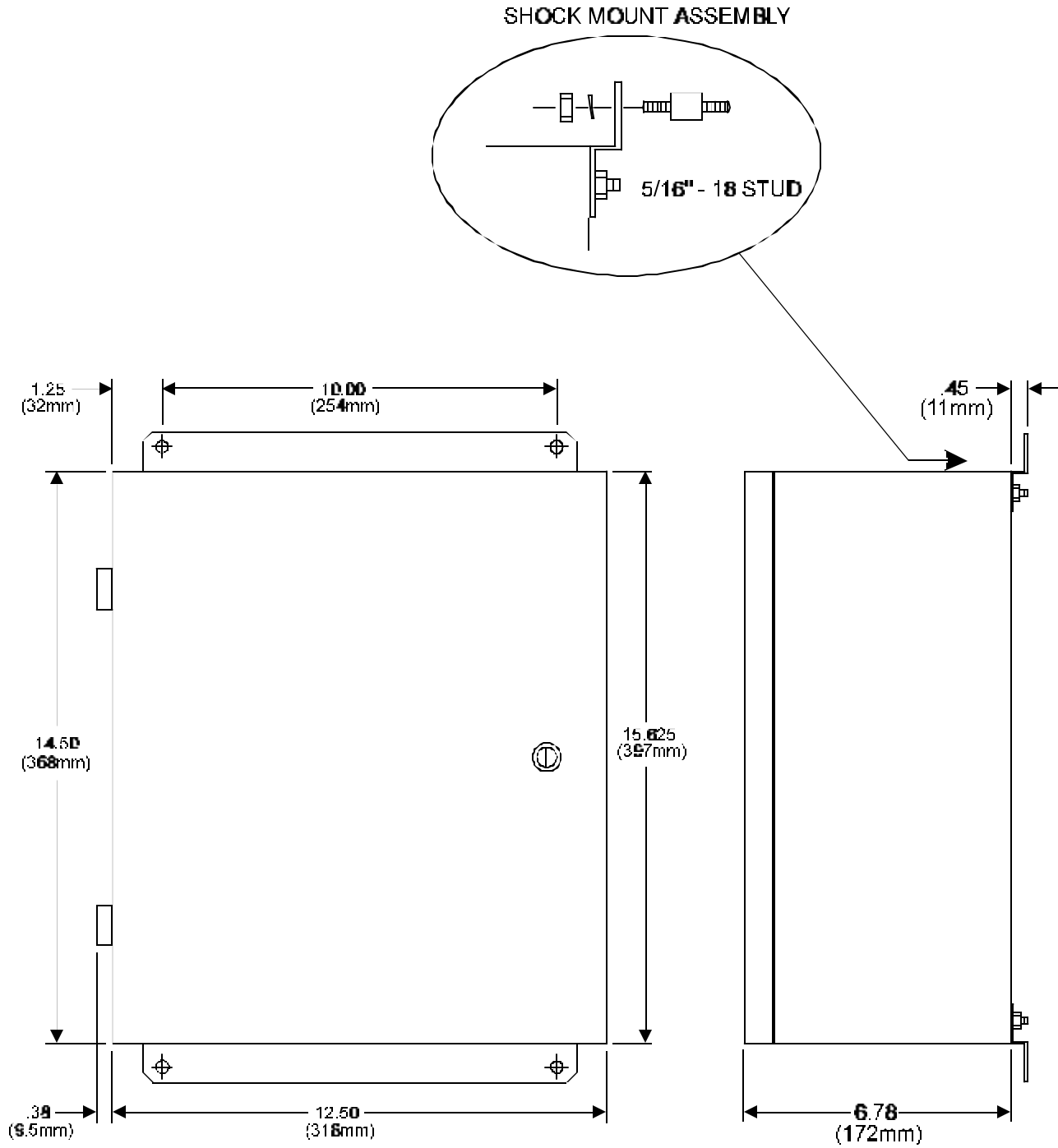

FIGURE 1

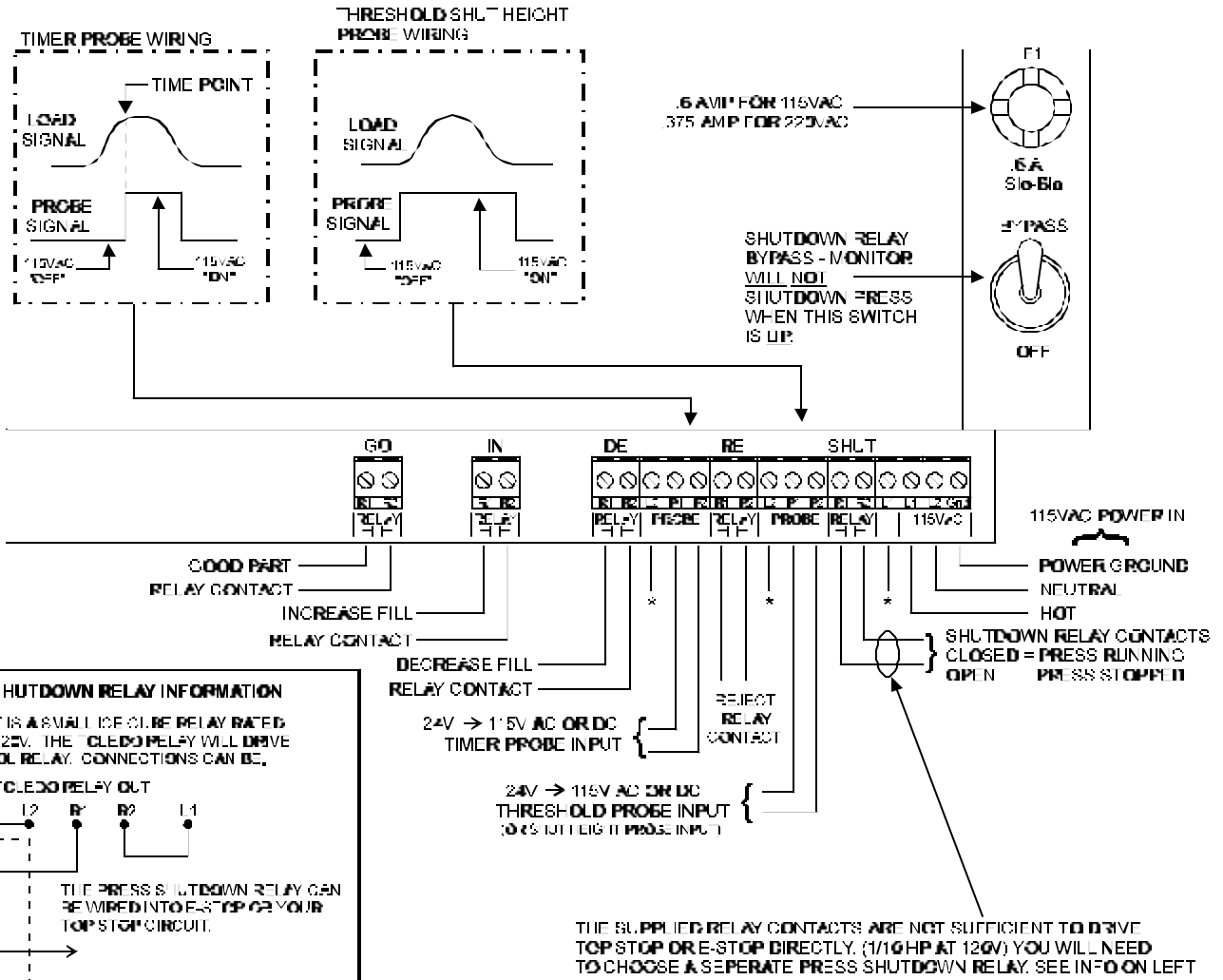
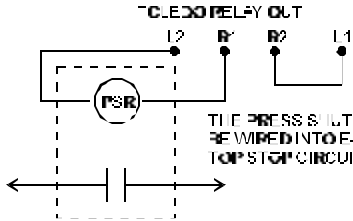

FIGURE 3

IMPORTANT PRESS SHUTDOWN RELAY INFORMATION

INSIDE THE N259 UNIT IS A SMALL ICE CUBE RELAY RATED AT 5 AMP, 1/16 HP AT 120V. THE ICE CUBE RELAY WILL DRIVE YOUR PRESS CONTROL RELAY. CONNECTIONS CAN BE:



THE SUPPLIED RELAY CONTACTS ARE NOT SUFFICIENT TO DRIVE TOP STOP OR E-STOP DIRECTLY. (1/16 HP AT 120V) YOU WILL NEED TO CHOOSE A SEPARATE PRESS SHUTDOWN RELAY. SEE INFO ON LEFT

FIGURE 3 Sensor Connections – N269 (RV7)

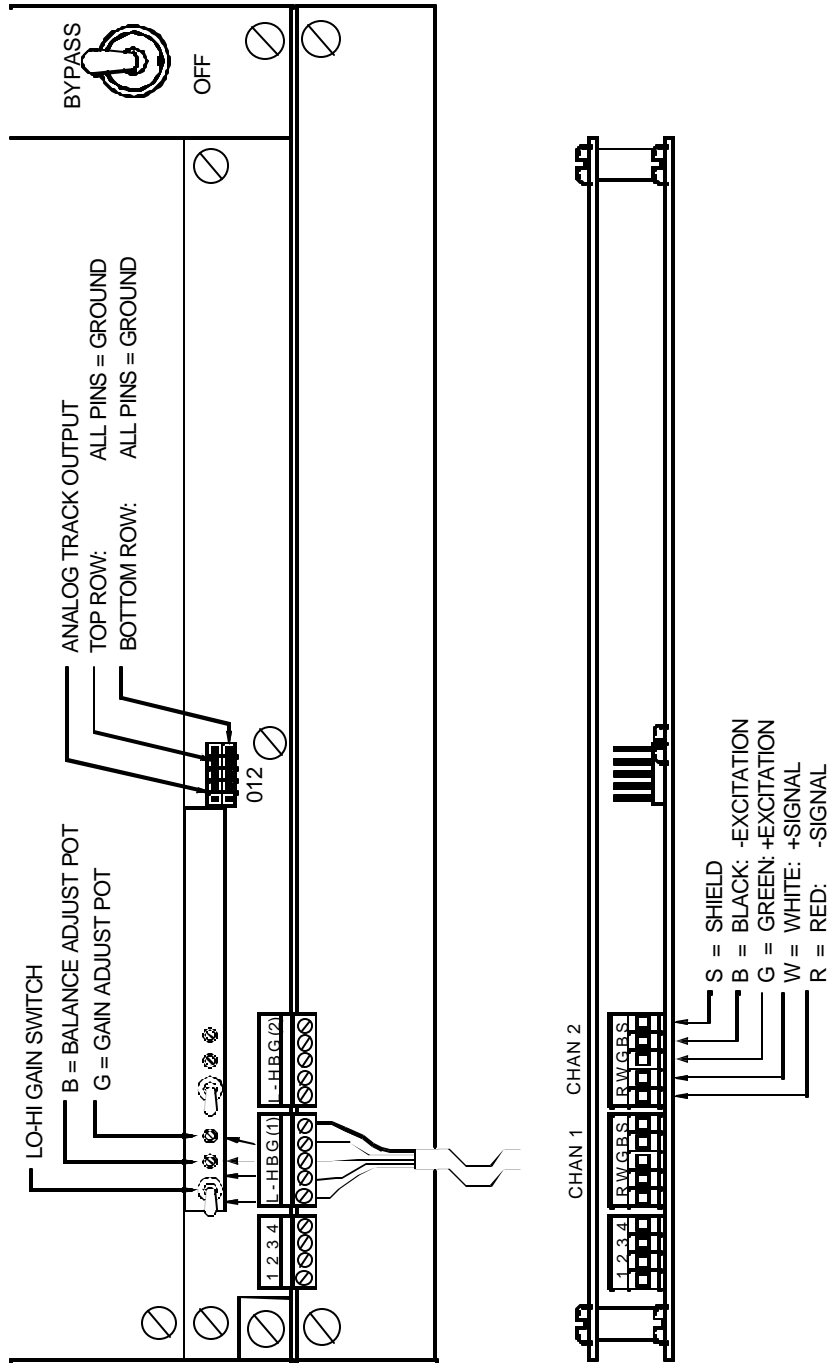

MAIN PC COMPUTER I/F HOOKUP AND SWITCHES - RV7 (N269)

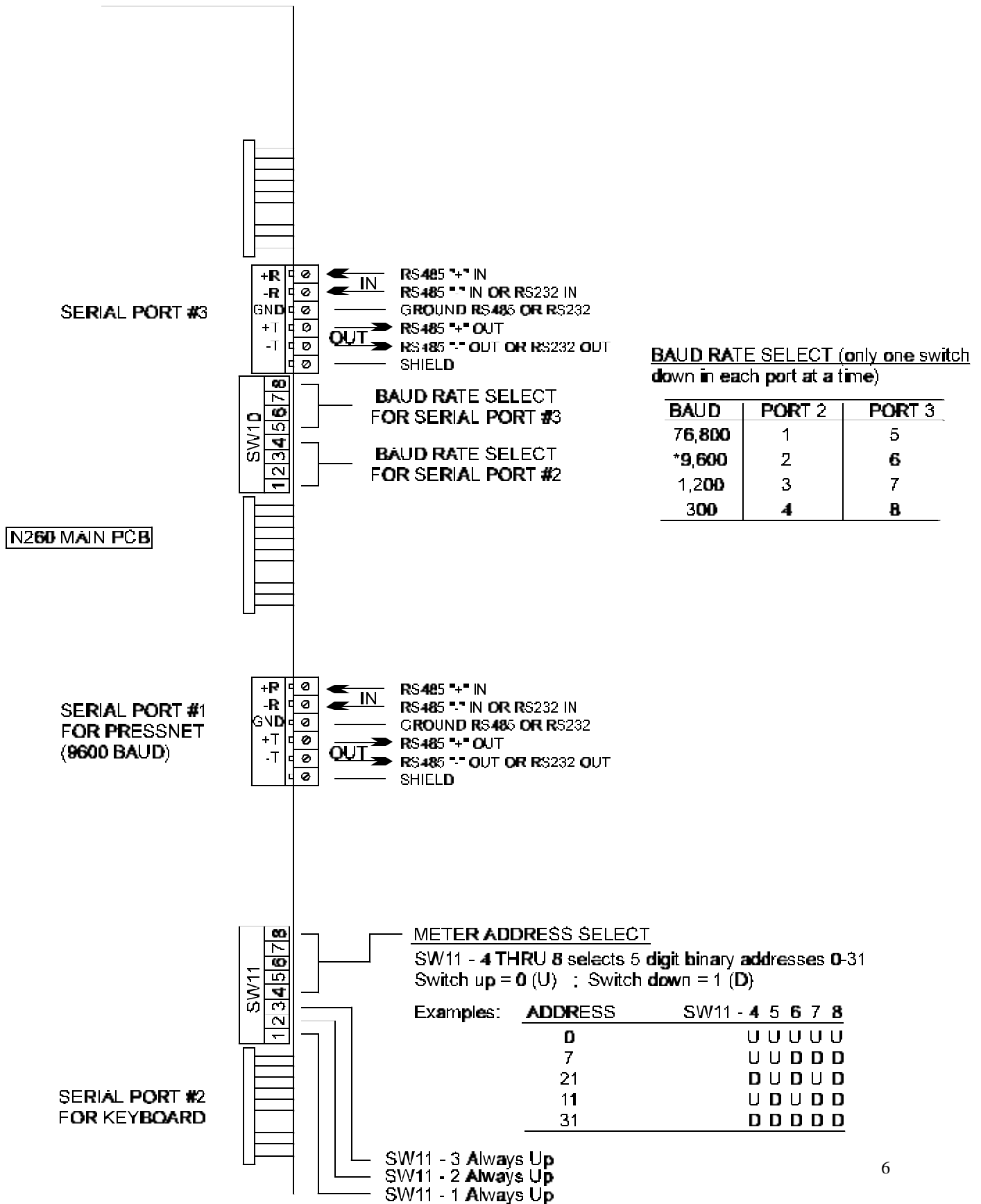

FIGURE 4

N269 FRONT PANEL

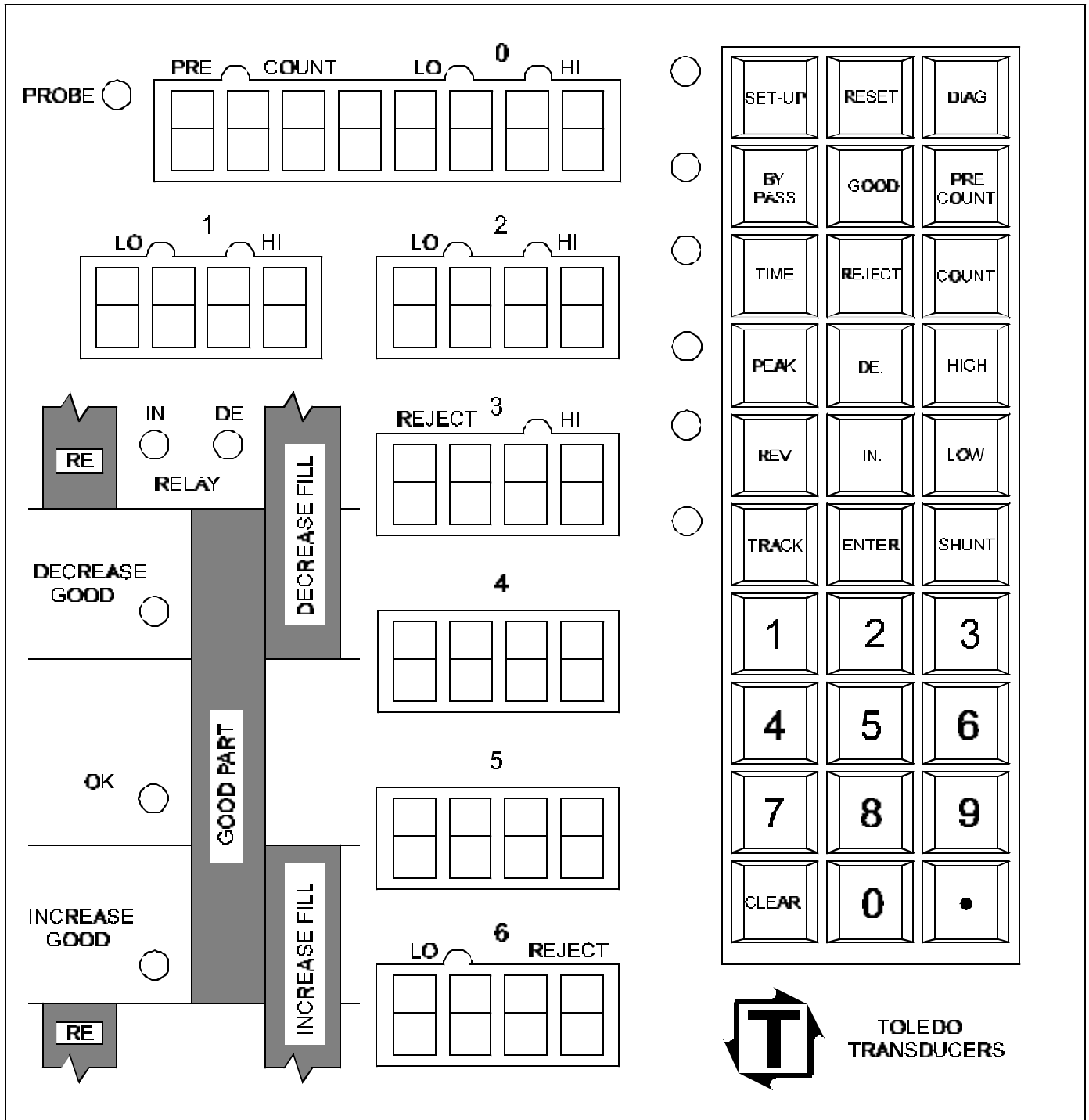

FIGURE 5

FIGURE 6 - Keyboard Jumpers and Switches

JUMPER SETTINGS

- J2 - TRANSMIT TO MAIN PC ENABLE
 POS. A = RS422
 POS. B = RS232
- J3 - TRANSMIT TO AUX. DISPLAY ENABLE
 POS. A = RS422
 POS. B = RS232
- J4 - RECEIVE FROM MAIN PC SELECT
 POS. A = RS422
 POS. B = RS232
- J5 - TRANSMIT TO MAIN PC SELECT
 POS. A = RS422
 POS. B = RS232

SWITCH SW31 SETTINGS

- #1 = DOWN (CLOSED)
 - #2 = UP (OPEN)
 - #3 = DOWN (CLOSED)
 - #4 & #5 = BAUD RATE SELECT FOR I/O TO & FROM MAIN PC
- | BAUD RATE | POS. 4 | POS. 5 |
|-----------|--------|--------|
| 76,800 | DOWN | DOWN |
| 9,600 | DOWN | UP |
| 1,200 | UP | DOWN |
| 300 | UP | UP |
- #6 = UP MASTER RESTART
 - #7 = UP UNUSED KEY SWITCH
 - #8 = UP SETTING CAPACITY
- (PUSH SWITCH #8 DOWN AND THEN UP BEFORE PRESSING "ENTER" TO CHANGE CAPACITY SETTING)

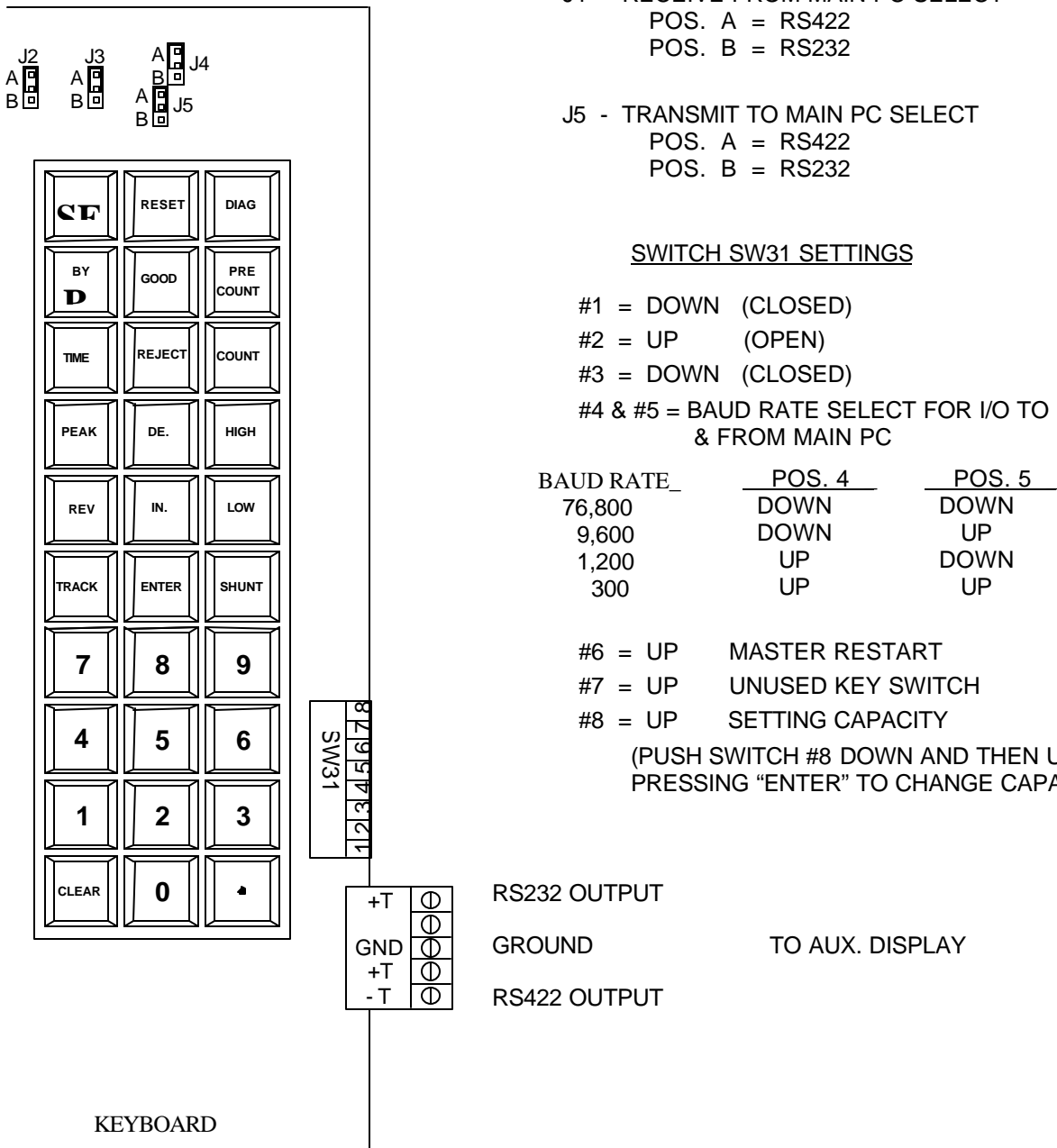
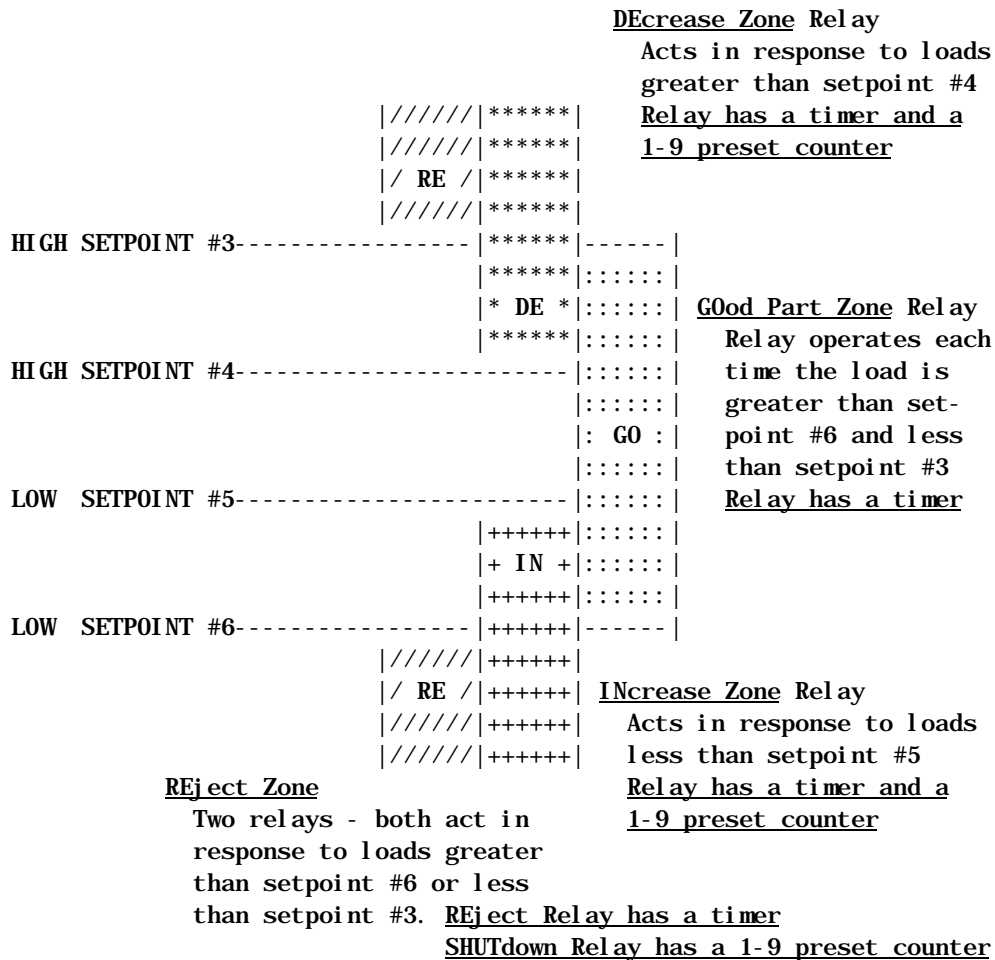

FIGURE 7 - N269 Process Control Zone Chart

This meter is designed to determine the peak load on each cycle of the press and respond to the load by operating the appropriate relays. The 4 variable setpoints establish the 5 zones shown on the sketch. For resolution and accuracy a 4 digit display shows the load.



The meter has 5 relays - 2 for the REject zone and 1 for each of the DEcrease, INcrease, and GOod part zones. One or two process control relays may operate at once depending on the load and preset counter values.

Three of the relays have their own 1-9 preset counters. For one of these relays to operate, the consecutive number of loads set on the preset counter must occur in its load zone. A number less than this will cause the count to start over. Thus, if the DEcrease zone preset counter is set to 3, the DEcrease relay would operate after 3 loads in a row above the #4 high setpoint.

Four of the relays have their own separate timers that control the length of time the relay remains operated. Thus, if the INcrease zone relay timer is set for .8 seconds and the INcrease relay operates it will remain operating for .8 seconds. These timers may be set to any time between 0 and 99.99 seconds.

N269 OPERATORS GUIDE

TURN ON POWER - The first time power is applied all values are set to 0.0 except for the following:

CAPACITY = 100.0 each chan THRESHOLD = 6.3 chan 0
HIGH SETPOINT = 100.0 each chan DIFFERENCE SET = 100.0 chan 0
LOWEST LOAD = 100.0 each chan COUNT HIGH SET = 100.0 chan 0
OPERATING MODE = PEAK mode PRESET COUNTERS = 1

ENTERING DECIMAL POINT and CAPACITY (Only necessary at 1st power-up)
Press **HIGH HIGH HIGH pt. (0-3) ENTER (0-2) (value) ENTER**

CHECKING CALIBRATION NUMBERS - (Sensor or cell must be connected)

1. press **TRACK** (Track LED comes on, peak LED goes off)
2. Zero each channel (0,1,2) by adjusting BALANCE pot (chans. 1,2)
3. press **SHUNT** (S appears in ch. 0, cal nos. appear in chans. 0-2)
4. Adjust GAIN pot chs. 1&2 to get proper cal nos. if not correct.
If the number will not go high enough switch to HIGH GAIN.
5. press **SHUNT** (S gone, ch. 0-2 = 0. If not=0, repeat steps 2-5)

OPERATING MODES - press **PEAK** (Peak LED comes on, track LED goes off)

SETUP MODE - press **SETUP** - LED toggles on/off - if on, in SETUP mode

REVERSE MODE - press **REV** - LED toggles on/off - if on, in REVERSE mode

AVERAGE TONNAGE DISPLAY - press **LOW COUNT 0 or 1 ENTER**

0 = no averaging, 1= average of 16 hits (L displayed in chan 0)

IME MODES - press **TIME TIME** - LED toggles on/off - LED on=TIME mode

to change the TIME mode press **TIME (0-3) ENTER**

0 = B4, 1 = FIRST LEVEL, 2 = SECOND LEVEL, 3 = POINT-IN-TIME

SETPOINT DATA

HIGH SETPOINTS

LOW SETPOINTS

TIME VALUE

BATCH COUNTER

THRESHOLD

COUNT HI SETPOINT

COUNT LO SETPOINT

To display press:

RESET HIGH

RESET LOW

RESET TIME

RESET PRECOUNT

LOW LOW LOW

HIGH COUNT

LOW COUNT

To change press:

CHAN # (value) ENTER

CHAN # (value) ENTER

0 (value) ENTER

(value) ENTER

0 (value) ENTER

0 (value) ENTER

0 (value) ENTER

COUNT & TIME DATA

COUNT

HI COUNTS

LO COUNTS

RATE in SPM

DOWNTIME

To display press:

RESET COUNT

COUNT HIGH

COUNT LOW

COUNT TIME

TIME COUNT

TONNAGE DATA

LAST ALARM

LAST HI ALARM

LAST LO ALARM

HIGHEST LOAD

LOWEST LOAD

To display press:

HIGH LOW

HIGH TIME

LOW TIME

RESET HIGH HIGH

RESET LOW LOW

RELAY TIMERS

To display press:

To change press:

GOOD PART RELAY	TIME GOOD	0 (value) ENTER
REJECT RELAY	TIME REJECT	0 (value) ENTER
DECREASE RELAY	TIME DE	0 (value) ENTER
INCREASE RELAY	TIME IN	0 (value) ENTER

<u>PRESET COUNTERS</u>	To display press:	To change press:
SHUTDOWN RELAY	TIME REJECT	. (0-9) ENTER
DECREASE RELAY	TIME DE	. (0-9) ENTER
INCREASE RELAY	TIME IN	. (0-9) ENTER

<u>ZONE COUNTERS</u>	To display press:
REJECT HI ZONE	COUNT REJECT HI
REJECT LO ZONE	COUNT REJECT LO
DECREASE GOOD ZONE	COUNT GOOD DE
INCREASE GOOD ZONE	COUNT GOOD IN
OK ZONE	COUNT GOOD GOOD
DECREASE ZONE COUNT	COUNT DE DE

<u>RELAY COUNTERS</u>	To display press:
GOOD PART	COUNT GOOD
REJECT	COUNT REJECT
DECREASE	COUNT DE
INCREASE	COUNT IN
INCREASE ZONE COUNT	COUNT IN IN

CHANGE FROM 0 TO 2 CHANS & BACK: **LOW LOW LOW . 0 or 2 ENTER**

RESETTING ALARMS: **RESET RESET RESET**

CLEARING ANY DATA: **CLEAR** - clears display to zero

CLEAR MEMORY: press and hold **CLEAR** - then press **RESET RESET RESET**

DIAGNOSTICS: each time **DIAG** is pressed new diagnostic info is shown when #=1, battery voltage is displayed

I. GENERAL DESCRIPTION - Refer to figure 7

The N269 process control load meter is used to control the variable material fill of a press on the basis of the peak load. System input can be from one or two strain gage bridge type sensors. In a single channel system the input is usually a load cell. Systems with two channels generally use two press frame mounted load sensors. When two sensor inputs are used, the side to side load as well as the total load is displayed by the N269. The peak load displayed in channel 0 is used to perform the process control functions. Five relays are used: four control the process and a fifth can shutdown the machine.

The N269 divides the range of loads into five zones using four process control setpoints. These setpoints, from the highest to the lowest, are labeled 3, 4, 5 & 6. All loads above #3 are considered high rejects and all loads below #6 are low rejects. A load value between #3 and #6 is considered a good part. Setpoint #4 must be set below #3 and above #6. Setpoint #5 is between #4 and #6. Any load above #4 is in the decrease zone and any load below #5 is in the increase zone. A load which falls between #4 and #5 is in the OK zone where no adjustment is made.

Any load in the reject zone (low or high) causes the REject relay to operate. Any load in the good zone (between #3 and #6) causes the GOod relay to operate. The INcrease and DEcrease relays have preset counters associated with each relay. In order for the DEcrease relay to operate the load must be in the decrease zone a number of times in a row determined by the setting of the decrease preset counter. The INcrease relay will operate only when the load has been in the increase zone the same number of times in a row as is set on the increase preset counter.

The REject relay has a preset counter as well. However, this counter determines the number of consecutive rejects which must occur before the machine is shutdown using the shutdown relay. Each process control relay (RE, DE, IN, GO) has a timer which determines the length of time for which the relay stays on. These timers may be set from 0 to 99.99 seconds in increments of .01 sec.

The machine can also be shutdown immediately in the event of a high load on either sensor input (channels 1 or 2 if more than one sensor input is used) or the total load (channel 0). The setpoints which determine the high shutdown load are the high setpoints #0, #1 and #2. When two sensor inputs are used, another setpoint is used to shutdown the machine if the difference in load between channels 1 and 2 exceeds this "difference" setpoint. This setpoint is the channel 0 low setpoint.

The N269 keeps track of many counts. Each of the five zones has an 8 digit counter. Each relay has an 8 digit counter which increments when the relay operates. All loads above setpoint #4 are counted (decrease zone) as well as all loads below #5 (increase zone) by 8 digit counters. Each high alarm setpoint and the difference setpoint has a 4 digit counter which counts these shutdowns. A stroke counter counts every press stroke (8 digits). Finally there is a predetermined counter (8 digit batch) which can be set to shutdown the press at the end of a certain number of parts.

Whenever a shutdown occurs, the channel 4 display shows the word "STOP" and the channel 5

display goes blank.

Several operating modes can be selected in addition to the normal peak mode. Setup mode disables all relays. Reverse mode shows any reverse loading taking place. A time delay starting at the beginning of the load cycle can be set to use the load at a particular point the stroke. First level mode is the peak load up to the time point. Second level mode is the peak load after the time point. The B4 mode combines first level and normal peak mode. In addition, the average load for the previous 16 strokes may be used for the process control. Finally, calibration is done in the track mode.

The N269 contains numerous additional features. Normally a threshold is used to sense the beginning of a cycle. Alternately a probe may be used. Another probe may be used to select a point in the stroke rather than the time delay described above. The N269 can display strokes per minute, the accumulated downtime (time since the last stroke), and the last alarm load value. The highest load and the lowest load is also stored in the memory.

All setup parameters and counts are stored in a battery backed up memory which will hold the data for years. A diagnostic routine indicates when the battery needs to be replaced. The diagnostics also indicate probe and relay status in addition to the software version number.

The N269 also has a built in high speed computer interface. RS232 or RS422/RS485 can be chosen with selectable speeds of from 300 to 76,800 baud. When using the RS422/RS485 interface up to 32 meters may be daisy chained on the same twisted pair cable. In this configuration each meter has a unique address which the computer uses to poll it in turn. The computer has all the capability that an operator has at the N269 keyboard. Information can be fully up or down loaded to and from the computer.

II. OPERATION

A. USING THE DISPLAY AND KEYBOARD - Refer to figure 5

At any given time the N269 will be showing one of three displays: the load for the last stroke according to the operational mode along with the process control setpoints, other information as requested by the user, or new data entered via the keyboard. These displays will be referred to as the load display, the data display, and the data entry display. These three displays only affect the user-N269 interaction. The operational modes discussed later affect the N269-press interaction.

1. LOAD DISPLAY

When power comes on initially the display is a LOAD DISPLAY. If this is the first time power was applied, PEAK operational mode is selected. Otherwise the meter is restored to the operational mode in use when the power went off. Whenever the "RESET" key is pressed the display returns to LOAD DISPLAY.

LOAD DISPLAY always shows the load from the last press stroke in channel 0. If there are two sensor inputs, the distribution load is displayed in channels 1 & 2. In addition, the process control setpoints are displayed in channel displays 3, 4, 5, & 6. One of the 5 zone LEDs is lit to indicate which zone the last stroke was in. If the press is stopped the word "stop" is displayed in place of the channel 4 setpoint and the channel 5 display is blanked. Other LEDs indicate any alarms which may have occurred on the last stroke.

2. DATA DISPLAY

When the operator requests data rather than a mode change, the display becomes a DATA DISPLAY. For example, if the N269 is displaying the PEAK load and you wish to view the HIGH SETPOINTS, pressing the proper key sequence puts the N269 display in DATA DISPLAY. This display is changed in one of three ways. If the "RESET" key is pressed, the display returns to LOAD DISPLAY. Likewise if no key is pressed, after about 13 seconds the display returns to LOAD DISPLAY. Or if a channel number is pressed while in DATA DISPLAY, the display changes to a DATA ENTRY DISPLAY.

3. DATA ENTRY DISPLAY

The display becomes a DATA ENTRY DISPLAY when a channel number key is pressed (0-9) or the decimal point key is pressed while the display is a DATA DISPLAY. DATA ENTRY DISPLAY may be distinguished from DATA DISPLAY by observing the operating mode indicator LEDs. When in DATA DISPLAY the operating mode LEDs are lit to indicate the operating mode. In DATA ENTRY DISPLAY these 6 LEDs are all off. In addition, only the channel in which data is being entered is displayed while all others are blank.

Once the proper channel for entry is selected, the data may be entered or changed. Using the number keys (0-9) or the decimal point key (.) new data may be entered directly. Pressing the "CLEAR" key will clear the data to 0.

When the DATA ENTRY DISPLAY shows the proper number to be entered, press the "ENTER" key to actually enter the value. Pressing "ENTER" does a number of things. First the number shown is stored in main memory. Then the display changes to DATA

DISPLAY with all channels lit once again, displaying what was displayed when they went blank during the last data entry. Now another channel may be selected and data entered, other data displayed, or load may be displayed once again by pressing "RESET".

DATA ENTRY DISPLAY may only be changed via the "ENTER" key or the "RESET" key. "ENTER" enters the value and returns the display to DATA DISPLAY. "RESET" changes the display to LOAD DISPLAY, continually showing the load in the operating mode selected.

4. KEY SEQUENCES

Data in the N269 meter is accessed from the keyboard using meaningful key sequences. A key sequence may consist of one, two or three keys pressed consecutively. Whenever a key is pressed, the data displayed depends not only on the key pressed but also on the last two keys pressed. To access data requiring key sequences of only one or two keys it may be necessary to press the "RESET" key before starting the key sequence.

B. USING THE PROCESS CONTROL FEATURES - Refer to figure 7

1. THE SETPOINTS AND ZONES

Four setpoints divide the load range into 5 process control zones. These setpoints are displayed in the channel 3, 4, 5, & 6 displays whenever a load is displayed in channel 0. Thus during normal operation the process control setpoints are displayed continuously.

Normally the setpoints are set such that setpoint #3 is greater than setpoint #4 which is greater than setpoint #5 which is greater than setpoint #6. Setpoints #3 and #4 are considered high setpoints and can be changed using the same key sequences used to change other high setpoints. Setpoints #5 and #6 are considered low setpoints and are changed the same way other low setpoints are changed.

All process control functions are based on the peak load in channel 0. REject occurs when the load is above setpoint #3 or below setpoint #5. Therefore a GOod part is when the load is between setpoints #3 and #6. The "DEcrease fill" function occurs when the load is above setpoint #4. The "INcrease fill" function occurs when the load is below setpoint #5.

These four setpoints are always displayed when loads are displayed except in the event of an alarm which stops the press. When the press is stopped, "STOP" is displayed in the channel 4 display and the channel 5 display is blank.

2. THE RELAYS

There are four process control relays in the N269 in addition to the normal shutdown relay. These relays are called the REject relay, the GOod part relay, the DEcrease fill relay and the INcrease fill relay. Each relay has a timer (0-99.99 seconds) which

determines how long the relay stays on when activated.

The REject relay operates at the end of the stroke if the channel 0 load was in either the high-reject zone or the low-reject zone. The GOod part relay operates at the end of the stroke if the channel 0 load was in the good zone. These two relays will never operate at the same time. Any load signal is either a reject or a good part so one of these two relays will operate on every stroke.

The DEcrease relay has a 0-9 preset counter associated with it. In order to operate the DEcrease fill relay the channel 0 load must be in the decrease zone for the same number of strokes in a row as is set on the DEcrease preset counter. For example, if the DEcrease preset counter is set at 3 then the channel 0 load must be in the decrease zone 3 strokes in a row for the DEcrease relay to operate. Any load signal above setpoint #4 is in the decrease zone. Thus it is possible to have the DEcrease relay operate when either the REject relay or the GOod part relay is operating.

The INcrease relay has a 0-9 preset counter associated with it. In order to operate the INcrease fill relay the channel 0 load must be in the increase zone for the same number of strokes in a row as is set on the INcrease preset counter. For example, if the INcrease preset counter is set at 4 then the channel 0 load must be in the increase zone 4 strokes in a row for the INcrease relay to operate. Any load signal below setpoint #5 is in the increase zone. Thus it is possible to have the INcrease relay operate when either the REject relay or the GOod part relay is operating.

The DEcrease and INcrease relays only operate at the end of a stroke. They are programmed to never operate at the same time even if the #4 and #5 setpoints are overlapped. If ever a situation arises in which both would logically operate, the N269 operates the DEcrease fill relay and does not operate the INcrease fill relay.

Another 0-9 preset counter exists for use with the shutdown relay. If the channel 0 load is in the reject zone (either high or low) a certain number of times in a row the shutdown relay opens to stop the press. Thus if this REject preset counter is set at 5 then at the end of 5 consecutive rejects the press will shut down.

In the event of a shutdown alarm, the DEcrease and INcrease relays will not operate. If the alarm was due to a high overload then the press was shut down immediately in the middle of the stroke. If this was the case, the REject and GOod part relays would not operate. If the alarm was a precount alarm (end of batch), a difference alarm, or a consecutive reject alarm the REject or GOod part relay will operate at the end of the stroke normally.

a. SETTING THE RELAY TIMERS--TIME (relay) 0 (data) ENTER

Each process control relay has a 0-99.99 second timer which determines how long the relay stays on. Initially upon power up this time is set to 0. When the time is 0 the relay

does not operate. To enable the process control relays to operate a time must be entered for each relay.

To enter a time for the GOod part relay press the keys:
TIME GOOD 0 (data) ENTER.

To enter a time for the REject relay press the keys:
TIME REJECT 0 (data) ENTER.

To enter a time for the DEcrease fill relay press the keys:
TIME DE 0 (data) ENTER.

To enter a time for the INcrease fill relay press the keys:
TIME IN 0 (data) ENTER.

b. SETTING THE RELAY PRESET COUNTERS--TIME (relay) Pt. (0.9) ENTER

There are three preset counters which can be set from 0 to 9: the DEcrease preset counter, the INcrease preset counter and the REject preset counter. The DE and IN preset counters control the operation of the fill relays while the RE preset counter controls the shutdown relay (excessive rejects).

To set the DEcrease preset counter press the following keys:
TIME DE .(dec pt.) (0-9) ENTER.

To set the INcrease preset counter press the following keys:
TIME IN .(dec pt) (0-9) ENTER.

To set the REject preset counter press the following keys:
TIME REJECT .(dec pt) (0-9) ENTER.

Preset counter settings of 0 are the same as settings of 1. At power up all preset counters are set to 1.

C. OTHER SETPOINTS

1. HIGH SETPOINTS - HIGH [#(0-4) (VALUE) [BYPASS] ENTER]

Each channel has a HIGH SETPOINT associated with that channel. When the load displayed for the operational mode selected exceeds the HIGH SETPOINT in channels 0, 1, or 2 the HIGH LED in that channel lights indicating an overload. If that HIGH SETPOINT is not bypassed and the meter is not in SET-UP mode the relay will open immediately to shut down the press. If an N269 has only one sensor input, the HIGH SETPOINTS in channels 1 & 2 are not used.

The HIGH SETPOINTS for channels 3 and 4 are two of the four process control setpoints. These setpoints are displayed continually in channels 3 and 4 as long as the load is displayed in channel 0. This means that during normal operation the process control setpoints are always

displayed. Setpoint #3 is the reject-hi setpoint and setpoint #4 is the decrease fill setpoint.

To display the HIGH SETPOINTS, press the "HIGH" key once. Remember that if this key is part of another valid sequence it may be necessary to press "RESET" once first. The HIGH SETPOINT for each channel will be displayed in its own channel. The HIGH LEDs will be lit in each channel to indicate that the HIGH SETPOINTS are being displayed. Low LEDs lit indicate bypassed HIGH SETPOINTS in the corresponding channel.

To enter new HIGH SETPOINT values press the number key (0-4) of the channel you wish to change. All displays will go blank except for the channel of interest. A new value may now be keyed in using number keys. Once the proper value is shown press "ENTER" to enter the data. The display will go back to displaying the HIGH SETPOINTS of all channels.

The HIGH SETPOINT of channels 0-2 may be bypassed selectively. If bypassed, when the load in a particular channel exceeds the HIGH SETPOINT of that channel the HIGH LED will light but the shutdown relay will not open. To bypass the setpoint, press the "BYPASS" key at any time while entering the HIGH SETPOINT value. Pressing the "BYPASS" key more than once will toggle that setpoint into and out of the BYPASS condition. The LOW LED in the channel indicates the status of the BYPASS. If the LOW LED is on then the channel is BYPASSED; if the LOW LED is off then the channel is NOT BYPASSED.

The display returns to displaying loads 13 seconds after the "ENTER" key is pressed or when the "RESET" key is pressed.

2. LOW SETPOINTS - LOW [#(0-2,5,6) (VALUE) [BYPASS] ENTER]

Each channel has a LOW SETPOINT associated with that channel. For meters with more than one sensor input, when the load displayed (for the operational mode selected) is less than the LOW SETPOINT in channels 1 and 2 the LOW LED in that channel lights indicating an underload. If that LOW SETPOINT is not bypassed and the meter is not in SET-UP mode the relay will open at the end of the stroke to shut down the press.

The LOW SETPOINTS in channels 5 and 6 are two of the four process control setpoints. These setpoints are entered in the same way that other low setpoints are entered. These, however, are continually displayed in channels 5 and 6 when the press is in normal operation. Setpoint #5 is the increase fill setpoint and setpoint #6 is the reject-lo setpoint.

To display the LOW SETPOINTS, press the "LOW" key once. Remember that if this key is part of another valid sequence it may be necessary to press "RESET" once first. The LOW

SETPOINT for each channel will be displayed in its own channel. The LOW LEDs will be lit in each channel to indicate that the LOW SETPOINTS are being displayed. Low LEDs not lit indicate bypassed LOW SETPOINTS in the corresponding channel.

To enter new LOW SETPOINT values press the number key (0-2,5,6) of the channel you wish to change. All displays will go blank except for the channel of interest. A new value may now be keyed in using number keys. Once the proper value is shown press "ENTER" to enter the data. The display will go back to displaying the LOW SETPOINTS of all channels.

The LOW SETPOINT of channels 0-2 may be bypassed selectively. If bypassed, when the load in a channel fails to reach the LOW SETPOINT of that channel the LOW LED will light but the shutdown relay will not open. To bypass the setpoint, press the "BYPASS" key at any time while entering the LOW SETPOINT value. Pressing the "BYPASS" key more than once will toggle that setpoint into and out of the BYPASS condition. The LOW LED in the channel indicates the status of the BYPASS. If the LOW LED is off then the channel is BYPASSED; if the LOW LED is on then the channel is not BYPASSED.

The display returns to displaying loads 13 seconds after the "ENTER" key is pressed or when the "RESET" key is pressed.

The channel 0 LOW SETPOINT in the N269 is not really a LOW SETPOINT. This setpoint is called the "difference" setpoint. It is used when the N269 is showing side to side loading in channels 1 and 2. This difference setpoint is really more like a high setpoint. If the load in channel 1 is different from the load in channel 2 by more than this difference setpoint, the meter will alarm and shutdown the press. This comparison is made at the end of the stroke and thus shutdown will not occur until after the stroke is finished. The difference setpoint applies only if more than one input is connected. For single input N269 meters, the LOW SETPOINT in channel 0 is not used.

This channel 0 LOW SETPOINT is entered and bypassed in the same way as other setpoints. The LEDs indicate in the same way as well.

3. RESETTING ALARMS - RESET RESET RESET

To reset the N269 meter from the alarmed condition (relay open) press the "RESET" key three times in a row. The shutdown relay will close enabling press operation and any LEDs indicating alarms will be turned off (high and low or precount).

In addition any process control relays still operating (on) will be immediately turned off. Thus this command may be used to terminate the operation of these relays.

D. COUNTERS

1. THE STROKE COUNTER - COUNT

Each load stroke of the press is counted. To display the COUNT press the "COUNT" key. "COUNT" is a part of several key sequences so you may need to press "RESET" before pressing "COUNT". The COUNT appears as an 8 digit number in channel 0. The COUNT is cleared to 0 by pressing the "CLEAR" key while the count is being displayed.

2. THE BATCH COUNTER - PRECOUNT [(VALUE) ENTER], COUNT PRECOUNT

The pre-determined batch counter may be set from 0 to 99,999,999. This counter counts down starting from the preset value every time a load stroke is made. When zero is reached, the PRECOUNT LED lights and the relay opens to stop the press. The shutdown feature may be bypassed so that only the PRECOUNT LED lights but the relay does not open when zero is reached. When zero is reached the counter is set again to the predetermined value for the next batch.

To set the counter press the "PRECOUNT" key. The pre-determined value is shown in the channel 0 display. To enter a new value simply enter the number and press "ENTER". In this case there is no need to press "0" before entering the value. To bypass the pre-determined counter press "BYPASS" before pressing the "ENTER" key.

The preset value of the pre-determined counter may be viewed at any time. This is done with the key sequence "COUNT-PRECOUNT". The value will be shown in the channel 0 display, and decreases with each load stroke of the press. When zero is reached, this counter is set back to the initial value.

When power comes on initially, the pre-determined count is set to 0. When set to 0, no counting or shut down occurs. So to disable the pre-determined counter after it has been in use simply enter a new value of 0.

3. THE PROCESS CONTROL COUNTERS

There are a total of eleven 8 digit counters associated with the process control N269 in addition to the stroke and batch counters (precount). These counters are all displayed in the channel 0 display using key sequences of two or three keys.

There are four relay counters. These counters count the number of times the particular relay is instructed to operate. They count only the actual relay operations. Thus if the N269 is in setup mode the relays do not operate and are not counted. Or if the relay time is set to 0 preventing relay operation the relay count does not increase.

To view the number of REject relay operations press:
COUNT REJECT

To view the number of GOod part relay operations press:
COUNT GOOD

To view the number of DEcrease relay operations press:
COUNT DE

To view the number of INcrease relay operations press:
COUNT IN

Each stroke of the press the channel 0 load falls into one of 5 zones determined by the 4 process control setpoints. Each of these 5 zones has a counter which increments whenever the load is in its zone. The key sequence consists of three keys always starting with count. Below are the sequences and the setpoints.

COUNT REJECT HIGH - (loads above setpoint #3)

COUNT DE GOOD - (loads between #3 and #4)

COUNT GOOD GOOD - (loads between #4 and #5)

COUNT IN GOOD - (loads between #5 and #6)

COUNT REJECT LOW - (loads below setpoint #6)

Two more counters round out the total of 11. One counter counts the number of strokes in the decrease zone (all loads above setpoint #4) and the other counts the strokes in the increase zone (everything below setpoint #5).

To view the decrease zone count press the key sequence:
COUNT DE DE .

To view the increase zone count press the key sequence:
COUNT IN IN .

4. THE ALARM COUNTERS

a. HIGH COUNTERS - COUNT HIGH

Each time the HIGH SETPOINT is exceeded by the operating mode load in a particular channel (0-2) this event is counted. A running total of HIGH ALARM COUNTS is thus kept for each channel. This counter counts up to 9,999 before rolling over to 0 again. The count increases regardless of the bypass status of the channels.

To display the HIGH ALARM COUNT, the key sequence is "COUNT HIGH". Channels 0-2 will now show the number of HIGH ALARMS which have occurred since the HIGH ALARM COUNT was last cleared. The HIGH LEDs are lit to indicate HIGH count as opposed to low count. To clear the counts,

press the "CLEAR" key while the counts are being displayed. The HIGH ALARM COUNT for each channel is cleared to 0. "ENTER" need not be pressed.

b. LOW COUNTERS - COUNT LOW

The LOW ALARM COUNTS are only valid for meters with more than one sensor input. Each time the LOW SETPOINT is not reached by the operating mode load in a particular channel (1 or 2) this event is counted. A running total of LOW ALARM COUNTS is thus kept for each channel. This counter counts up to 9,999 before rolling over to 0 again. The count increases regardless of the bypass status of the channels. Channel 0 indicates the number of difference alarms which have occurred.

To display the LOW ALARM COUNT, the key sequence is "COUNT LOW". Each channel now show the number of LOW ALARMS which have occurred since the LOW ALARM COUNT was last cleared. The LOW LEDs are lit to indicate LOW count as opposed to high count. To clear the counts, press the "CLEAR" key while the counts are being displayed. The LOW ALARM COUNT for each channel is cleared to 0. "ENTER" need not be pressed.

E. ADDITIONAL OPERATING MODES

1. SET UP MODE - SET-UP

When in SET-UP mode the N269 will monitor each stroke and indicate out of tolerance conditions in the display (high and low LEDs) but will not shut down the press when an out of tolerance load occurs. If one stroke is out of tolerance causing an alarm LED to light and the next stroke is in tolerance, the lighted LED will go out. This mode is intended for use in set up operations to prevent nuisance shutdowns. **IN THIS MODE EXCESSIVE OVERLOADS WILL NOT SHUTDOWN THE PRESS UNDER ANY CIRCUMSTANCES.**

The zone LEDs light to indicate the zone in which the load falls but the process control relays do not operate. Thus when the N269 is in SET-UP mode none of the relays will operate.

2. TIME MODE - TIME TIME

a. DESCRIPTION OF TIME MODE

The TIME mode selects one of four special operating modes which are used with the TIME value described above. The meter is in the TIME mode when the TIME LED is lit. The TIME LED may be toggled on and off by pressing the TIME key twice. When the TIME LED is on, load displays show the TIME mode digit in the left portion of the channel 0 display.

To select a different TIME mode (0-3) press the TIME key followed by the DEC. PT. key. The display will show a single 0-3 digit indicating the present TIME mode. Press a new number (0-3) to set the proper TIME mode then press ENTER. The following table shows the mode corresponding to each number.

<u>TIME mode number</u>	<u>Special operating mode</u>
0	B4 mode
1	First level mode
2	Second level mode
3	Point-in-time mode

b. SETTING THE TIME VALUE - TIME [0 (VALUE) ENTER]

A TIME VALUE may be entered which, when used with TIME mode described below, can show the peak load for various portions of the stroke. The timer starts at the time the meter is triggered (via THRESHOLD or PROBE INPUT) and continues until the number of seconds equal to the TIME VALUE has elapsed.

To display the TIME VALUE press the "TIME" key once. Channel 0 will show a number 0 to 99.99. This is the TIME VALUE in seconds. To change the value, press "0" and enter the new value. Press "ENTER" to finish the entry process. The maximum delay which can be entered is 99.99 seconds.

c. THE POINT-IN-TIME-MODE

The N269 meter can be set-up to display the load at a particular point in the stroke. This can be accomplished in a variety of ways. The most common way utilizes the time value as a delay from the point at which the load signal crosses the threshold at the start of loading. Thus when the amount of time since the threshold crossing elapses, the meter reads the load value and stores this number in the memory.

Another way to trigger this point-in-time reading is very similar to the above method. If a probe is used in place of the threshold, the point-in-time becomes the time at which the time value occurs having started its timing when the probe indicated the start of the load signal.

The last way to gather this point-in-time data is by using a probe dedicated exclusively to this point-in-time function. When the TIME VALUE is set to zero and the meter is in the TIME mode this probe is enabled. Then whenever the probe turns on the meter stores the load seen at this time in the memory.

To display the Point-In-Time load the meter must be in TIME mode number 3. Press the keys RESET TIME in that order. The display will show the TIME VALUE in channel 0 (X.XXX) and a single digit number to the left of this value. The single digit number is a number from 0 to 3. It is this number which determines the time mode number. Press the DEC. PT. key to select this

single digit number. Press the number 3 key. Now press ENTER. The meter is selected for time mode number 3 but may not yet be selected for TIME mode itself. If the TIME LED is lit, the meter is already in TIME mode. Just press RESET and the Point-In-Time load will be displayed. If the TIME LED is not lit, press the TIME key twice to light the TIME LED thus putting the meter in TIME mode.

Now with the Point-In-Time mode selected, every stroke of the press will display the loading at this point in time. With the TIME mode selected, high and low setpoints will apply to this load and alarms will be determined now on the basis of the load at the point in time. In addition the process control operates on the basis of what the channel 0 load was at the point in time.

d. THE FIRST LEVEL LOAD

The FIRST LEVEL load is the peak loading which occurs during the portion of the stroke from the initial threshold crossing until the time point is reached.

To use the FIRST LEVEL load mode, the TIME VALUE must first be set. See the section concerning TIME VALUE for more information on how to do this.

The proper TIME mode must also be selected to see the FIRST LEVEL loading. FIRST LEVEL is TIME mode #1. To set the TIME mode, press TIME the DEC. PT. and the number 1 to select TIME mode #1. Press ENTER to enter this number.

Now unless the meter is in TIME mode, the FIRST LEVEL loads will not be shown. The meter is in the TIME mode when the TIME LED is lit. If this LED is lit, nothing more needs to be done-the meter should now display the FIRST LEVEL loads. If the meter is not in TIME mode (Time LED not lit) press TIME twice and the TIME LED should light.

When the meter is in the FIRST LEVEL mode, the high and low setpoints apply to the FIRST LEVEL load. The process control also takes place on the basis of the first level load in channel 0.

e. THE SECOND LEVEL LOAD

The Second Level loading is the peak load which occurs in each channel between the TIME point and the end of the stroke. To display the Second Level loading the meter must be put into the TIME mode 2. When in this mode, setpoints will apply to the loads displayed.

To select the Second Level mode, press the key sequence RESET TIME. Now press the DEC. PT. key. Press the number 2 key. Press ENTER to enter the value. If the TIME LED is lit press RESET. If not lit press TIME twice. The TIME LED must be lit to select the Second Level mode.

f. THE B4 MODE

The B4 mode is a combination of the normal peak mode and first level mode. This mode is meaningful only for presses with more than one sensor input. When selected the B4 mode displays the distribution forces at the first level time in channels 1 and 2. Then when the punch finishes the stroke the total load is displayed in channel 0. In this way setpoints may be set on the first level load using channels 1 and 2 as well as on the total load using channel 0 for the same stroke of the press.

To select the B4 mode the meter must be in TIME mode 0. Press the keys RESET TIME. The display will now show the TIME VALUE in channel 0 and the TIME mode digit to the left of the TIME VALUE. Press the DEC. PT. key and then the 0 key. Press the ENTER key to enter the number. If the TIME LED is lit just press RESET to display loads again. If the TIME LED is not lit press the TIME key twice and then RESET. Once the TIME LED is lit the meter is in TIME mode and with TIME mode and with TIME mode 0 selected the display shows B4 loads.

Setpoints will now apply to the loads which are displayed. This means that channels 1 and 2 cover the distribution load and channel 0 covers the total load. Therefore the process control is on the basis of the total load when in B4 mode. For more information about the TIME VALUE refer to its own discussion elsewhere in the manual.

3. AVERAGE LOADS

The N269 meter can be set to display the average of the previous 16 press strokes rather than displaying each stroke if desired. Averages for any operating mode can be shown, but only the average of the present operating mode is calculated for each press stroke. This means that it will require 16 strokes in a particular mode before the meter will be showing accurate averages. When the display is showing average loads the high and low setpoints trigger off of these averages for alarms. The process control setpoints use the channel 0 average load to determine the zone of the signal.

To enter the averaging mode, press the key sequence LOW COUNT DEC PT. (.). The meter display will show a single digit in the left portion of the channel 0 display. This digit will be a 0 when the meter is NOT in the averaging mode. To put the meter in average mode press the 1 key. Then press the ENTER key. After 13 seconds elapses or after RESET is pressed the meter will show the average load of the last 16 strokes. In the far left portion of the channel 0 display the "L" will appear to indicate that the meter is displaying average load.

To go back to displaying normal loads use the above procedure to set the single digit average number back to zero.

4. REVERSE MODE - REV

The REVERSE mode changes the polarity of the input analog signal. The main use of this mode is to read "snap-through" loading which occurs primarily in blanking operations. To enter REVERSE mode press the "REV" key. The REVERSE LED will light indicating the mode change. Pressing the "REV" key again will take the meter out of REVERSE mode extinguishing the REVERSE LED.

If the N269 is in PEAK mode and in REVERSE mode, any setpoints entered will be disabled. Thus the meter cannot be used to shut down the press or do any process control when in the REVERSE mode. The REVERSE mode is provided mainly as a diagnostic tool.

When switching into and out of REVERSE mode when in PEAK mode, wait 10 seconds after the change before operating the press. This will give the N269 enough time to recalculate an accurate baseline.

F. OTHER SETTINGS

1. THE STROKE COUNTER SETPOINTS

The counter has a high and a low setpoint which may be set to enable the counter to count only those strokes with load greater than the low setpoint and less than the high setpoint. These setpoints operate on the basis of the load in channel 0. So to count the stroke the channel 0 load must exceed the low count setpoint but not the high count setpoint. In addition, the N269 will not do any process control unless the load in channel 0 is greater than the low count setpoint.

To set the low setpoint use the key sequence LOW COUNT 0. Only the counter low setpoint will be displayed in channel 0. A new value may be entered using the number keys. When finished altering press ENTER to enter the new value. The initial value of the low count setpoint is 0.

To set the high setpoint use the key sequence HIGH COUNT 0. Only the counter high setpoint will be displayed in channel 0. A new value may be entered using number keys. When finished altering press ENTER to enter the new value. Initially the high count setpoint is set to capacity.

2. CLEARING THE N269 MEMORY

The memory of the N269 can be cleared to its initial state with a special key

sequence at the keyboard. When this is done, all memory values are cleared to 0 except for the CAPACITY, the DECIMAL POINT number, the THRESHOLD, the TIME value, and the MAXIMUM CHANNEL number. A few other values are set to the same value they would have if they had never been entered. The high setpoints are set to capacity in each channel. The preset counters are all set to 1. The lowest low loads are set to capacity in each channel. The high setpoint for the counter is set to the capacity of channel 0.

To clear the memory to the initial state press and hold the CLEAR key. While holding the CLEAR key down press the RESET key three times in a row. The N269 will now be set to its initial condition. This establishes a known base from which changes can be made to set-up parameters.

G. OTHER INFORMATION

1. THE LAST ALARM

Whenever an alarm occurs in channels 0-2 of the N269 meter, the information shown in the display is saved in the memory. This information is stored as the Last Alarm and is changed whenever another alarm occurs. This information about the Last Alarm can be recalled to the display by pressing the proper key sequence at the keyboard.

To display the Last Alarm load information press the key sequence HIGH LOW or LOW HIGH. The display will show the load which occurred in each channel for the press stroke that caused the alarm. Pressing the CLEAR key at this time will clear the data to zero in each channel. Pressing RESET will call up the load from the last press stroke.

2. THE LAST HIGH ALARM

Whenever a high alarm occurs in channels 0-2 of the N269 meter, the information shown in the display is saved in the memory. This information is stored as the Last High Alarm and is updated whenever another high alarm occurs. This information about the Last High Alarm can be recalled to the display by pressing the proper key sequence at the keyboard.

To display the Last High Alarm load information press the key sequence HIGH TIME. The display will show the loading which occurred in each channel for the press stroke that caused the high alarm. Pressing the CLEAR key at this time will clear the data to zero in each channel. Pressing RESET will call up the load from the last press stroke.

3. THE LAST LOW ALARM

Whenever a low alarm occurs in channels 0-2 of the N269 meter, the information shown in the display is saved in the memory. This information is stored as the

Last Low Alarm is updated whenever another low alarm occurs. This information about the Last Low Alarm can be recalled to the display by pressing the proper key sequence at the keyboard.

To display the Last Low Alarm load information press the key sequence LOW TIME. The display will show the loading which occurred in each channel for the press stroke that caused the low alarm. Pressing the CLEAR key at this time will clear the data to zero in each channel. Pressing RESET will display the load from the last press stroke.

4. THE HIGHEST LOAD

The highest load seen in a particular channel (0-2) is stored in the N269 memory. To display this information press the key sequence RESET HIGH HIGH. The display will show the highest load that each channel has seen. The numbers shown for the various channels could have occurred on different strokes of the press and therefore must be considered to be unrelated to one another.

To clear these values press the CLEAR key at any time while they are being displayed. The display will then show 0 in each channel until the next press stroke occurs.

5. THE LOWEST LOAD

The lowest load seen in a particular channel (0-2) is stored in the N269 memory. To display this information press the key sequence RESET LOW LOW. The display will show the lowest load that each channel has seen. The numbers shown for the various channels could have occurred on different strokes of the press and therefore must be considered to be unrelated to one another.

To clear these values press the CLEAR key at any time while they are being displayed. The display will then show capacity in each channel until the next press stroke occurs. The values are set to capacity rather than to 0 to be sure that we properly detect low values including a load as low as 0.

6. THE PRODUCTION RATE IN STROKES PER MINUTE (SPM)

The speed of the press may be displayed as a 4 digit number in strokes per minute. To display the strokes per minute press the key sequence RESET COUNT TIME. The channel 0 display will now show the press speed based on the last two strokes in strokes per minute.

7. THE DOWN-TIME (Time Since the Last Stroke)

The N269 keeps track of the time which has elapsed since the last press cycle occurred. This time since the last stroke is an indication of the down time. Every

time a new stroke occurs this time is reset to 0. To display the down time, press the key sequence TIME COUNT. The channel 0 display will show three numbers separated by spaces. These numbers are from left to right, days, hours, and minutes since the last stroke. When the time reaches 100 days the display rolls over to zero.

8. THE DIAGNOSTICS

The DIAG key is used to display some elementary diagnostic information. Pressing the DIAG key will show one of ten pieces of diagnostic information in channel 0. A single digit (0-9) appears in the left display to indicate which info is being displayed. The information appears in channel 0 as a 4 digit value. Every time the DIAG key is pressed the DIAG digit is incremented to show the next diagnostic information. The following table explains what each digit means.

<u>DIGIT</u>	<u>DATA</u>	<u>DESCRIPTION</u>
0	XXXX	Main PC ROM checksum
1	X.XXX	Battery voltage in volts- replace if less than 2.5 volts or greater than 4.0 volts
2	1111	Status of probe inputs 7,6,5,4 1=off, 0=on
3	1110	Status of probe inputs 3,2,1,0 Input #0 = power status Input #1 = threshold probe Input #2 = time point probe
4	0111	Status of relay outputs 1,2,3,4 Output #1 = SHUTdown relay Output #2 = REject relay Output #3 = DEcrease relay Output #4 = INcrease relay
5	1111	Status of relay outputs 5,6,7,8 Output #5 = GOod part relay 1=off, 0=on
6	XXXX	Thumbwheel inputs-- Leftmost digit=SW11,1-4 Next digit=SW11, 5-8 SW11-1 = binary track display SW11-2 = checksum checking on input data SW11, 3-8 = meter address Next digits=Thumbwheels 1&2
7	XXXX	Thumbwheel inputs 3,4,5,6
8	XXXX	Thumbwheel inputs 7,8,9,10
9	XXXX	Thumbwheel inputs 11,12,13,14

III. INSTALLATION

A. MOUNTING THE ENCLOSURE - Refer to figure 1

The N269 meter comes in a 14x12x6 green enclosure and should be mounted on or near the press so as to be easily seen by an operator. USE THE 4 SHOCK MOUNTS PROVIDED when mounting the enclosure to protect the electronic assemblies from excessive vibration.

All wiring connections to the N269 are made through the bottom of the enclosure and should use flexible conduit. Do not run AC (power or relay) lines and sensor cables in the same conduit.

B. AC & POWER CONNECTIONS - POWER,RELAY,PROBE- See figure 2

The N269 meter requires continuous and filtered 115VAC power at 60 Hz. for proper operation. Power consumption is less than 40 watts. In the event of AC power failure, a small battery located on the N269 main PC board will retain the present information stored in memory for a period of years.

Often the AC power provided at the press is not suitable for electronic equipment such as the N269. We recommend a separate AC line to power the N269 if possible, additional filtering of the AC power line may be necessary to obtain good performance of the meter.

To expose the AC power connections, open the N269 enclosure door and remove the rectangular plate from the bottom of the cabinet. Behind the plate is the power supply circuit board containing the connections for AC power, the 5 control relays, and the 115VAC probe inputs. The wires must enter the enclosure through a hole situated behind this plate. The AC power line is connected to the rightmost 3 terminals labeled L1, L2, and GND. Connect a good earth ground to the terminal labeled "GND". Connect the hot side of the AC line to the terminal labeled "L1" and the neutral side to "L2". A one amp fuse protects the system and is electrically connected on the "L1" or "hot" side.

The press shutdown relay contact connection is to the left of the AC power connection on the terminal strip through terminals labeled R1 and R2. This contact is normally closed, but opens in the event of an alarm OR the loss of AC power. The contact rating is 5 amps at 115VAC. The BYPASS switch on the chassis is connected across the relay contact. When in "BYPASS" (switch up) the switch shorts the relay contacts preventing shutdown even if an alarm or AC power failure occurs.

The connections to the process control relays (RE,DE,IN & GO) are all labeled R1 and R2. In addition the appropriate two letter designation is found below the terminal strip contacts. These contacts are normally open. The contacts close when the relay is energized at the proper time. All relay contacts are rated at 5 AMPS/115VAC.

The connections to the probes are optional. Most applications will not use probes. If you are using them, each probe input has two terminals labeled P1 and P2. When the probe is "on" there should be 115 VAC across P1 and P2. When the probe is "off" the voltage should be 0. Normally some type of contact which switches the AC on and off is wired to these probe input terminals. Extra L1 and L2 terminals are provided if a source of 115 VAC is needed for

connection to the probes. See Figure 2 for more information.

C. SENSOR HOOKUP - Refer to figure 3

Sensors should be wired with the power OFF. If the meter has already been powered up power can be shut off by removing the fuse. All sensor connections are made to the N269 main PC board through removable 5 pin terminal blocks. Terminals on both the stationary and removable portion of the block are color coded to match the sensor cable color code for normal tension measurements. R=RED,W=WHITE,G=GREEN,B=BLACK,O=ORANGE/SHIELD.

The color code is correct for SENSORS IN TENSION or for LOAD CELLS IN COMPRESSION. Reverse the GREEN and BLACK wires for sensors in compression or if the load cell spec. sheet says to do so. If only one input device is to be connected, wire it into channel 1.

The fifth terminal labeled "0" is for the shield and ground connection. Load cells and T400 sensors have 4 wires plus the shield. Connect the shield to terminal "0". The T400-A amplified sensor has a fifth wire colored orange plus the shield. Connect both the orange wire and the shield on the T400-A to the terminal labeled "0". DO NOT under any circumstances reverse the RED and WHITE wires of the T400-A sensor.

A small 3 pin header with a 2 pin jumper block is located on the main PC board above each sensor input connector. This jumper selects the type of sensor the channel can accept. With the jumper block pushed into the lower 2 pins the channel accepts regular T400 sensors, load cells and wheatstone bridge type sensors. The meter is shipped from the factory with the jumper in this position. To select the T400-A sensor in this channel carefully remove the jumper from the bottom 2 pins and transfer to the top 2 pins. In this way each channel may be individually selected for the proper type of sensor input.

D. POWERING THE METER UP

When power is initially applied to the N269, minimal amount of information is needed before accurate loads may be displayed. Once this set up information is entered, if power is lost the internal battery maintains this information in memory. If this power up configuration is not done immediately, the meter may still be used because values are automatically assigned to these variables to enable limited operation.

AT POWER UP:

CAPACITY	=	100.0 in each channel
HIGH SETPOINT	=	100.0 in each channel
THRESHOLD	=	6.3 in channel 0

OPERATING MODE	=	PEAK
PRESET COUNTERS	=	1 for each relay
LOWEST LO TONS	=	100.0 in each channel
CNT HI SETPOINT	=	200.0 in channel 0

All other data is set to 0.

Before using the N269 meter to accurately monitor tonnages the following must be done:

1. Enter press CAPACITY including the proper DECIMAL POINT location
2. BALANCE each channel
3. Set calibration numbers in each channel

These 3 steps will have been done during calibration. You may wish to verify that the proper numbers have been entered if this is the case. Once the CAPACITY is initially entered it will never need to be re-entered unless the memory is lost. (i.e. battery fails for some reason).

E. INITIAL SETTINGS

1. DECIMAL POINT LOCATION - HIGH HIGH HIGH [. (0-3) ENTER]

To display the number of DECIMAL PLACES press the key sequence HIGH-HIGH-HIGH. A single digit appears in the left portion of the channel 0 display. This digit indicates the number of decimal places to the right of the decimal point in the displays. The number can be 0 (in which case no point is displayed), 1, 2 or 3 places.

To change this number, press the decimal point key. This digit only will now be lit. Press the number key (0-3) which corresponds to the number of decimal places desired. Now press the "ENTER" key. The display will now show the CAPACITY again.

2. PRESS CAPACITY - HIGH HIGH HIGH [#(0-2) (DATA) ENTER]

Press capacity is displayed by press the key sequence HIGH-HIGH-HIGH. The capacity of each channel is displayed in that channel. New values may be entered by selecting a channel (0-2), entering the data value, pressing keyboard DIPSWITCH #31-8 down and then up (see Fig. 6), and pressing ENTER. For meters with only one input device, the press capacity gets entered into channel 0. If two sensors are connected, the capacities entered into channels 1 & 2 should be half of press capacity.

Upon power up if the CAPACITY has not yet been set, each channel is set to the value 100.0 to indicate percentage. THE DISTRIBUTION CHANNELS WILL NOT ADD UP PROPERLY UNTIL CAPACITIES ARE ENTERED IN CHANNELS 0-2.

3. TRIGGERING THE METER

a. THE THRESHOLD - LOW LOW LOW [0 (VALUES) ENTER]

The N269 meter must be triggered to know when the load signal is applied and then

relieved. This triggering can be either internal or external to the meter. The internal method is by the use of the THRESHOLD.

The THRESHOLD is the minimum total load which must be generated in channel 0 before the signal is recognized as a load signal. To view the THRESHOLD press the LOW key three times in a row. The THRESHOLD is displayed in channel 0. This value can be changed by pressing the "0" number key followed by the new value followed by the "ENTER" key. The value of the THRESHOLD when power comes on is 6.3% of capacity (channel 0). We recommend THRESHOLD values of at least 3% of capacity.

b. THE PROBE INPUT - LOW LOW LOW [0 CLEAR ENTER]

The N269 meter can be triggered externally by the use of a 115VAC signal applied to the probe input terminals. To trigger this way 115VAC must be switched on at these terminals just before the load comes on and then removed just after the load comes off. This 115VAC OFF-ON-OFF signal triggers the meter for acquisition of the peak load. See installation instructions for wiring information about the probe input.

The N269 is set up to use the THRESHOLD method unless told otherwise. To select external triggering with the probe, enter a THRESHOLD value of 0. This tells the N269 to use the probe input rather than the THRESHOLD for triggering.

4. THE MAXIMUM CHANNEL NUMBER - LOW LOW LOW [. (0,2) ENTER]

To display the MAXIMUM CHANNEL NUMBER press the key sequence LOW-LOW-LOW. The MAXIMUM CHANNEL NUMBER appears as a single digit in the left portion of the channel 0 display. This digit is an indication of the highest numbered channel being processed and displayed by the N269. Normally this number will correspond to the highest channel number of the meter. This number will be two if there are two sensor inputs and 0 when there is only one sensor input. When this number is set to 0 the channel 1 & 2 displays are blank.

If you wish to display only the total load on a meter which has two sensors connected this can be done. The meter must be calibrated and set up with this MAXIMUM CHANNEL NUMBER set at 2. This number can then be changed to force the N269 meter to process and display only the channel 0 load. The channel 1 & 2 displays will be blank and the process control setpoints will continue to be displayed in channels 3-6.

To change the MAXIMUM CHANNEL NUMBER displayed, press the "." (decimal point) key while the THRESHOLD is being displayed. The THRESHOLD will disappear from the display and only the MAXIMUM CHANNEL NUMBER displayed will be shown. Press the 0 key or the 2 key to change this number, and then press "ENTER" to enter the new value into memory.

5. TRACK (calibration) MODE - TRACK

In TRACK mode the raw signal from each sensor scaled to the CAPACITY is shown in its corresponding channel. Channel 0 shows the total of channels 1 and 2. When only one sensor is connected (into channel 1) channel 0 shows that single sensor signal. Each channel (1 & 2) can be BALANCED to zero by adjusting its BALANCE pot. To enter TRACK mode press the "TRACK" key. The TRACK LED will light and the PEAK LED will go out. Track mode is used primarily for calibration.

6. THE CALIBRATION SHUNT - SHUNT

The SHUNT is used to generate a reference number in each channel which is used as the calibration number for that channel. It is most often used in "TRACK" mode to properly set the gain in each channel. The shunt can, however, be used in PEAK mode as well by cycling on and off to generate a simulated load signal.

This key switch alternately engages and disengages the calibration shunt resistor in each channel. Pressing the "SHUNT" key once will engage the shunt. An "S" is displayed in the third digit from the left of channel 0 to indicate the shunt being engaged. Pressing the "SHUNT" key again will disengage the shunt and the "S" will disappear from channel 0. Although each channel uses a separate shunt resistor all shunts are simultaneously engaged or disengaged with the "SHUNT" key switch.

Each channel has one shunt resistor which has a value of 1MEG. If the N269 meter is replacing a different type of meter or if a load cell or sensor has been calibrated using different valued shut resistor a new calibration number will have to be calculated. This is must be done because the N269 shunts are not removable. They are permanently soldered into the main PC board.

7. PEAK MODE - PEAK

In PEAK mode the peak load generated during the last load cycle is displayed in each channel. Channels 1 and 2 show the load distribution. Channel 0 shows the total channels 1 and 2 when there are two sensor inputs or the peak load with just one input. The total channel 0 displays the peak of the sum of the distribution channels 1 & 2 based on time. Therefore if the peaks of the distribution channels do not occur at the same instant in time, channels 1 & 2 will not add up to channel 0. However, the value shown in channel 0 is a better representation of the actual peak load seen by the press during the stroke than the sum of the peaks shown in the distribution channels 1 & 2.

When the meter display updates showing the load for the stroke one of the 5 zone LEDs lights to indicate which process control zone the channel 0 tonnage was in.

PEAK mode is entered by pressing the "PEAK" key. When pressed, the PEAK LED will light and the TRACK LED will go out. The PEAK values of the last load cycle will be displayed in each channel. Peak is the normal operating mode of the N269 meter.

F. CALIBRATION

The N269 meter must be calibrated to display accurate load values generated by the machine. BEFORE EACH CHANNEL CAN BE CALIIBRATED IT MUST HAVE THE PROPER CAPACITY ENTERED. If this has not been done yet, refer to the section concerning capacity in the previous portion of the manual.

Each channel has three adjustments which must be made to calibrate the meter. These are the BALANCE pot, the GAIN pot, and the LOW-HIGH GAIN switch. There are a number of ways to calibrate the meter as discussed below. All involve using one precision shunt resistor (1 meg +/- .1%) per channel switched across one leg of each input channel's strain-gage bridge to generate a reference (calibration) number.

1. PRE-CALIBRATED LOAD CELLS

When a pre-calibrated load cell is the input for a particular channel, the calibration number has already been determined at the factory. This number is normally included in a spec. sheet shipped with the load cell. The cal number, however, is dependent upon the value of the shunt resistor. If the cal number, on the spec sheet is for a shunt different than the 1 MEG shunt used in the N269 a conversion must be made. When the proper number is determined, the BALANCE and GAIN must be adjusted to read this number on the channel associated with the load cell.

Put the meter in "TRACK" mode by pressing the "TRACK" key on the keyboard. Be sure all load cells are properly wired into the channel terminal blocks. Set the LOW-HIGH GAIN switch to LOW or HIGH as required by the load cell spec. sheet in the channel being calibrated. Using a small screw driver adjust the BALANCE pots (labeled "B") so that each channel reads 0 in the display. Turning clockwise causes numbers to increase.

Now depress the key labeled "SHUNT" on the keyboard. You should see an "S" appear in the left portion of the channel 0 display. This indicates that the shunt is engaged. Adjust the GAIN pot (labeled "G") until the calibration number is seen in the channel display corresponding to that load cell. Depress the shunt key again and the "S" should disappear from channel 0. Each channel should now display 0. If not, BALANCE the channel to zero again using the BALANCE pot and then engage the shunt again. Adjust the GAIN pot if needed to display the proper calibration number again. Dis-engage the shunt and read 0 in the display.

It is possible that the LOW-HIGH GAIN switch will need to be in a different position for normal meter operation than it is when setting the calibration number. Check the spec. sheet and if necessary change the setting of the LOW-HIGH GAIN switch. A normal operation mode may now be selected.

2. CALCULATED CALIBRATIONS

If the precise area of the member to which the strain gage is attached is known, sometimes a calculated calibration can be given. In this case a specification sheet is provided showing the proper calibration numbers for each channel. Also shown on this sheet is the proper setting of the LOW-HIGH GAIN switch for both calibration and normal operation. Follow the same procedure followed for pre-calibrated load cells to set in the proper calibration numbers.

3. ON SITE CALIBRATION USING REFERENCE LOAD CELLS

The meter may also be calibrated by using pre-calibrated load cells placed in the bed of the press and the N114 portable load monitor. The procedure is to develop a known load on the load cells of about press capacity evenly distributed among the cells and adjust the GAIN of the N269 meter so that the channel readings match those of the load cells.

Put the N269 in "TRACK" mode and BALANCE each channel to 0. Place the N269 in "PEAK" mode and in "SETUP" mode. Strike the load cells and adjust the shut-height and/or shim the cells until the N114 shows an evenly distributed capacity load on the press. Now adjust the GAIN pot and if necessary the LOW-HIGH GAIN switch of each channel so that on each press cycle the N269 reads the same as the N114. When each channel of the N269 reads the same as the corresponding channel of the N114 and the totals match, the meter is calibrated.

Now the calibration number for each channel must be recorded. Put the N269 meter in "TRACK" mode. Seal the GAIN pot of each channel with nail polish so that it will not be adjusted any more. Adjust the BALANCE pot of each channel so that each channel reads 0. Push the "SHUNT" key to engage the shunt ("S" appears in channel 0). Record the reading displayed in each channel - this is the calibration number for that particular sensor. Also record the position of the LOW-HIGH GAIN switch for each channel. Push the "SHUNT" key once more to disengage the calibration shunt for operation.

If the calibration number is less than 25% of the capacity of a particular channel, a better calibration number with more resolution can be obtained by switching from LOW to HIGH GAIN on the LOW-HIGH GAIN switch for CALIBRATION PURPOSES ONLY. If this is desired, re-BALANCE the meter with the shunt dis-engaged, re-engage the shunt, and then record this new calibration number. Be sure to record that this cal number is valid for HIGH GAIN and CALIBRATION only. Return the GAIN switch to the LOW position for normal operation. This cal number will be exactly 10 times the value recorded in the LOW GAIN position. Disengage the shunt before operating the press.

A operating mode may now be selected.

G. COMPUTER INTERFACE HOOKUP - Refer to figure 4

The N269 can be connected to a computer using the built-in RS232 or RS422/RS485 serial interface. Connection is made with a 5 pin connector (like the sensor input

connector) located at the right edge of the main PC board. This connector is labeled:

- T + GND - R +.

1. RS422/RS485 INTERFACES

The wires to the computer should consist of three twisted pairs with an overall shield. We recommend BELDEN #8013 cable for this application. One pair is connected to the + and - transmit (T) terminals, a second pair connects to the + and - receive (R) terminals, and the third pair connects to the center (GND) terminal. The shield connects to other compute cable shields and then floats at the meter. The transmit terminals are outputs from the N269 to the computer while the receive terminals are inputs from the computer to the N269. The '+' is the non-inverting terminal and '-' is the inverting terminal.

2. RS232 INTERFACES

This connection is made to the computer with a single pair of shielded wires. The terminal labeled -T is the transmit line from the N269 to the computer. The terminal labeled -R is the receive line from the computer to the N269. The shield can be connected to the center (GND) terminal.

3. SETUP PARAMETERS

The N269 transmits data in blocks to the computer at speeds from 9600 to 115,200 baud. Traditional modem signals are not used - therefore the computer must be able to accept data from the N269 continuously at the speed selected for the interface. Likewise the N269 expects data to come from the computer continuously as a block with no dead time between characters. This must be considered when selecting the baud rate.

Any one of four baud rates may be selected for the interface: 9600, 38400, 76800, Or 115200 baud. The baud rate for the interface is DIP switch SW10, positions #3 and #4.

The last setting needed to complete the computer hookup is the meter address selection. When using RS422/RS485, up to 32 N269 meters may be daisy-chained on the same serial line. To do this, the computer must know how to uniquely identify each meter on the line. This is accomplished by assigning each meter on a particular line a six digit binary address of 0 to 31. DIP switch SW11 selects this address. SW11 is located just above the connection to the

computer at the right edge of the main PC board.

Switches #4-#8 of SW11 select this address. The following example shows the proper switch settings for various meter addresses. **DO NOT SELECT THE SAME ADDRESS FOR MORE THAN ONE METER ON EACH RS422 LINE.**

SW 11	-	#8	Down	=	1
SW	-	#7	Down	=	2
SW	-	#6	Down	=	4
SW	-	#5	Down	=	8
SW	-	#4	Down	=	16

To obtain an address 1 simply have SW11 - #8 down. To obtain an address of 3 simply put #8 and #7 down. Every switch downward will sum a higher address value. If all the switches were set downward you would have an address of $1+2+4+8+16=31$. Therefore with the address of 00000, there are a total of 32 addresses available.

IV. TROUBLESHOOTING INFORMATION

A. USING THE OUTPUT JACK - Refer to Fig. 3

The N269 meter has an analog track output signal for each channel. This output is

located in the lower middle section of the main PC board. There are two rows of pins: the front (lower) row of pins is the analog output for the channels starting with channel 0 at the left end; the rear (upper) row of pins is the signal ground. These pins are such that scope probe may be clipped to the pin or a mating connector may be attached to all pins for sending the signals to a recorder, etc.

The signal level is 0 volts when the channel is balanced to zero in the no-load condition. A capacity load represents a positive change of 5.0 volts. The output impedance is 1000 ohms. Due to temperature changes in the sensing devices the no-load signal will drift causing small shifts in the output voltage at the output jacks. The span, however (5.0V=capacity), will remain constant.

B. SYMPTOMS AND SOLUTIONS

DISPLAY WILL NOT LIGHT

1. Check AC power to meter - 115VAC \pm 15% 60Hz.
2. Check fuse
3. Check for loose cables between chassis and display board, etc.
4. Check DIP switch and jumpers on keyboard
5. Check DIP switch and jumpers on main board
6. Check power to PC boards - +5VDC, +15VDC, +12VDC

MEMORY LOST WHEN POWER LOST

1. Check battery - loose? or bad (must be greater than 2.5 VDC)
2. Check 50 pin ribbon cable from power PC to main PC

V. N269 SERIAL COMMUNICATIONS PROTOCOL FOR COMPUTER INTERFACING

A. HARDWARE CONNECTION - See installation instructions

B. TRANSMISSION CHARACTERISTICS

All data is ACSII characters
9 selected asynchronous baud rates
1 start bit, 8 data bits, 1 stop bit
Modem controls not used
Maximum information block size - 256 bytes
Data must be transmitted as a block - no pause allowed

C. RECORD CONSTRUCTION - 3 parts: Header,Data,Trailer

1. HEADER: 2 bytes - Always 1st and 2nd byte transmitted

Byte 1 = 0-9 (30-39 HEX) Address of meter for RS422/RS485
muti-drop configuration
This is set via DIP switch
on main PC board

Byte 2 = "+" (2B HEX) Start of record indicator

2. TRAILER: 5 bytes - Always follows data portion of record

Byte 1 = "(" (28 HEX) Indicates start of checksum

Byte 2 = 0-9 (30-39 HEX)
A-F (41-46 HEX) 1st digit of checksum

Byte 3 = 0-9 (30-39 HEX)
A-F (41-46 HEX) 2nd digit of checksum

Byte 4 = ")" (29 HEX) Indicates end of checksum

Byte 5 = cr (OD HEX) Carriage return

3. Data - COMPUTER GENERATED

The data portion of the record is made up of data requests, data entry, etc. This consists of a data type character followed by a command character.

a. DATA TYPE CHARACTER - @,A,B---Z,[,\,],^,_ (40-5F HEX) 32 possible

b. COMMAND CHARACTER - (20-39 HEX) Presently 8 possible

"!" (21 HEX) Clear DATA TYPE data to zero

" (22 HEX) Send DATA TYPE data - with spaces

"#" (23 HEX)	Reset alarmed condition in N269
"%" (25 HEX)	Clear all memory to initial state
' (27 HEX)	Send data without spaces (like ")
"-" (2D HEX)	Enter mode information (8 digits)
"." (2E HEX)	Enter HIGH LED info (4digits)
"/" (2F HEX)	Enter LOW LED info (4digits)
"0-9" (30-39H)	Enter chan info by type (4digits)

Numerous requests can be contained within the data portion of the record as well as data entry, reset, etc.

c. ENTRY DATA

The ENTRY DATA consist of digits 0-9 and some special characters (30-3F HEX). The ENTRY DATA must follow the appropriate entry command and all digits must be filled (4 or 8) as the N269 expects the number of digits to match the data type. Immediately following the last digit of every must come either the next data type character or the start of checksum indicator.

NOTE: Even though up to 248 bytes may be transmitted by the computer in the data portion of the record, care must be used so as not to request more than 256 bytes of data from the N269 at a time. An error will result if this is not done.

d. DATA TYPE CHARACTER

@	= Undefined	
A	= Average load	0000 to 9999
B	= Relay timers and Presets	0000 to 9999
	CHAN 0 = Reject Hi timer	0000 to 9999
	CHAN 1 = Decrease timer	0000 to 9999
	CHAN 2 = Increase timer	0000 to 9999
	CHAN 3 = Good timer	0000 to 9999
	CHAN 4 = Reject preset	0000 to 0009
	CHAN 5 = Decrease preset	0000 to 0009
	CHAN 6 = Increase preset	0000 to 0009
C	= Capacity of the press	0000 to 9999
D	= Delay time value	0000 to 9999
E	= Undefined	
F	= First level load	0000 to 9999
G	= Highest high alarm	0000 to 9999
H	= High setpoints	0000 to 9999
	CHAN 3 = Reject HI	0000 to 9999
	CHAN 4 = Decrease	0000 to 9999
I	= Last high alarm	0000 to 9999
J	= Last alarm	0000 to 9999
K	= Lowest lo alarm	0000 to 9999

L = Low and Dif setpoints	0000 to 9999	
CHAN 0 = Difference	0000 to 9999	
CHAN 5 = Increase	0000 to 9999	
CHAN 6 = Reject Lo	0000 to 9999	
M = Last lo alarm	0000 to 9999	
N = Normal peak load	0000 to 9999	
O = Undefined		
P = Point in time load	0000 to 9999	
Q = B4 mode load	0000 to 9999	
R = Reverse peak load	0000 to 9999	
S = Second level load	0000 to 9999	
T = Track values	-999 to 9999	
U = 8 digit counts		
CHAN 3 = Good relay	0000 to 9999	upper 4 digits
CHAN 4 = Good relay	0000 to 9999	lower 4 digits
CHAN 5 = Reject relay	0000 to 9999	upper 4 digits
CHAN 6 = Reject relay	0000 to 9999	lower 4 digits
V = 8 digits counts		
CHAN 3 = Good Decrease	0000 to 9999	upper 4 digits
CHAN 4 = Good Decrease	0000 to 9999	lower 4 digits
CHAN 5 = Reject Decrease	0000 to 9999	upper 4 digits
CHAN 6 = Reject Decrease	0000 to 9999	lower 4 digits
W = 8 digit counts		
CHAN 3 = Good Increase	0000 to 9999	upper 4 digits
CHAN 4 = Good Increase	0000 to 9999	lower 4 digits
CHAN 5 = Reject Increase	0000 to 9999	upper 4 digits
CHAN 6 = Reject Increase	0000 to 9999	lower 4 digits
X = High alarm count	0000 to 9999	
Y = Low alarm count	0000 to 9999	
Z = 8 digit counts		
CHAN 0 = Decrease relay	0000 to 9999	upper 4 digits
CHAN 1 = Decrease relay	0000 to 9999	lower 4 digits
CHAN 2 = Increase relay	0000 to 9999	upper 4 digits
CHAN 3 = Increase relay	0000 to 9999	lower 4 digits
CHAN 4 = OK zone count	0000 to 9999	upper 4 digits
CHAN 5 = OK zone count	0000 to 9999	lower 4 digits
[CHAN 0 = Threshold	0000 to 9999
	CHAN 1 = Count hi setpoint	0000 to 9999
	CHAN 2 = Count lo setpoint	0000 to 9999
	CHAN 3 = Strokes per min.	0000 to 9999
\	CHAN 0 = Main PC ROM sum	0000 to 9999
	CHAN 1 = Battery voltage	0000 to 4999
	CHAN 2 = Analog gnd voltage	0000 to 9999
	CHAN 3 = I/O status	0000 to ????(30 HEX to 3F HEX)

] CHAN 0 = Batch counter 0000 to 9999 upper 4 digits
 CHAN 1 = Batch counter 0000 to 9999 lower 4 digits
 CHAN 2 = Time since last dd0hh0mm total 8 digits
 CHAN 3 = Time since last dd=days, hh=hours, mm=minutes
 CHAN 4 = Decrease zone cnt 0000 to 9999 upper 4
 digits
 CHAN 5 = Decrease zone cnt 0000 to 9999 lower 4 digits
 ^ CHAN 0 = Batch count value 0000 to 9999 upper 4 digits
 CHAN 1 = Batch count value 0000 to 9999 lower 4 digits
 CHAN 2 = Stroke counter 0000 to 9999 upper 4 digits
 CHAN 3 = Stroke counter 0000 to 9999 lower 4 digits
 CHAN 4 = Increase zone cnt 0000 to 9999 upper 4 digits
 CHAN 5 = Increase zone cnt 0000 to 9999 lower 4 digits
 _ = Thumbwheel switches 16 digits as 4x4 digits

4. DATA - N269 GENERATED

a. RECORD - [Header (2)], Data Type (1), Command (1), Mode (8), High LED (4), Low LED (4), Chan 0 (4), Chan 1 (4),...Chan N (4), Data Type (1), Command (1), High LED (4), Low LED (4), Chan 0 (4),..., Chan N (4),[Trailer (5)]

The N269 data portion of the record starts with 2 bytes indicating data type and command (command will either be 22 HEX or 27 HEX). Then the 8 digit mode is sent followed by the high LEDs, low LEDs, and channel data depending on the data type selected. The channel data is sent starting with channel 0 then continuing to the highest channel the system uses (6).

EX: N269 - Sends channels 0,1,2,3,4,5,6

If more than one data type was requested, immediately following the last digit of the last channel the next data type and command are sent. However, THE MODE INFORMATION (8 BYTES) IS NOT RE-SENT. Next come high LEDs (4), lo LEDs (4), Chan 0 (4), Chan 1 (4), etc. as before.

The above assumes data without spaces was requested (command = ' = 27 HEX). If data with spaces is requested (command = " = 22 HEX) then a space follows the command byte, and then every 4 data bytes are followed by a space.

b. MODE CONSTRUCTION - 8 BYTES (30-3F HEX)

BYTE 1: Indicates Maximum channel number for N269 (0 or 2)

BYTE 2: Indicates number of decimal places in load data (0-3) 0=XXXX
1=XXX.X 2=XX.XX 3=X.XXX

BYTE 3: Indicates count mode (0-3)

BYTE 4: Indicates time mode (0-3)

BYTE 5: Indicates average mode (0-3)

BYTE 6: If 0, relay closed. If 1, relay open, press stopped.

BYTE 7: Bits 0-3 indicate status of 4 items 0011XXXX
Bit 3 = Shunt engaged? 1=yes, 0=no-----^ | | |
Bit 2 = Batch alarm? 1=yes, 0=no-----^ | |
Bit 1 = First level? 1=yes, 0=no-----^ | |
Bit 0 = Reverse? 1=yes, 0=no-----^

BYTE 8: Bits 0-3 indicate status of 4 items 0011XXXX
Bit 3 = Peak mode? 1=yes, 0=no-----^ | | |
Bit 2 = Track mode? 1=yes, 0=no-----^ | |
Bit 1 = Set-up mode? 1=yes, 0=no-----^ | |
Bit 0 = Any bypassed? 1=yes, 0=no-----^

c. HIGH AND LOW LED CONSTRUCTION (4 BYTES 30-3F HEX EACH)

```

HIGH LEDs -      00110000 00110000 0011000X 0011XXXX
                  |           | | | |
Reject Hi zone-----^           | | | |
Decrease relay-----^           | | | |
CHANNEL 2-----^           | | | |
CHANNEL 1-----^           | | | |
CHANNEL 0-----^           | | | |
    
```

X -- 1 = LED ON, 0 = LED OFF

```

LOW LEDs -      00110000 00110XXX 00110X00 0011XXXX
                  | | | |           | | | |
Decrease good zone-----^ | | | |           | | | |
Lo reject zone-----^ | | | |           | | | |
Increase good zone-----^ | | | |           | | | |
OK zone-----^ | | | |           | | | |
Increase relay-----^ | | | |           | | | |
CHANNEL 2-----^ | | | |           | | | |
CHANNEL 1-----^ | | | |           | | | |
CHANNEL 0 (Difference)-----^ | | | |
    
```

X --- 1 = LED ON, 0 = LED OFF

d. LED CONVENTIONS

In most cases, LED information will be zeroes. For load data types A,F,N,P,Q and S the LEDs on indicate an alarm in channels 0-2, the proper zone or a fill relay operation. If the N269 is in set-up mode, the alarms will not shut down the press. Also if that particular channel is bypassed in the setpoint which caused the alarm, the meter will not shutdown the press. To determine which channels are bypassed the LOW LED information must be examined for both the lo and hi setpoints. For bypassed high setpoints the data indicates a "1" in the proper channel location of the low LED information. This is only true of channels 0-2. Normally for high setpoints the low LED info is all zeroes. Normally for low setpoints the low LED info is all ones. For bypassed low setpoints the data indicates a "0" in the proper channel location of the low LED information.

e. NUMBERS

THRESHOLD - The load generated in channel 0 must exceed this value before the stroke is recognized as valid. If this is 0, the meter uses the probe to trigger on.

DELAY TIME - Wait in seconds from triggering point (threshold or probe) before the peak is read.

BATCH SETPOINT, BATCH COUNT, STROKE COUNTER - 8 digit numbers stored as two 4 digit values.

THUMBWHEEL SWITCHES - Four 4 digit (0-9) values (total of 16)
Digit 1 = Setting of SW11, 1-4 (main PC)
Digit 2 = Setting of SW11, 5-8 (main PC)
(This is the meter address)
Digit 3-16 = 14 Thumbwheels on door in order in which they appear

TIME SINCE LAST STROKE - 8 digits indicating down time in days, hours, and minutes.

I/O STATUS - Total of 4 digits, each digit represents 4 bits
First two digits represent status of inputs
Next two digits represent status of outputs
1=device OFF 0=device ON

ALL OTHER NUMBERS ARE 0000-9999 THE LOAD USES THE DECIMAL POINT GIVEN IN THE MODE INFORMATION.

f. CHECKSUM CALCULATION

The checksum is an 8 bit modulo 256 sum of every ASCII byte in the record starting with and including the 1st digit meter address, and ending with and including the start of checksum indicator "(" . This modulo 256 sum is then given a 2 digit HEX representation and changed to ASCII for transmission. The checksum is always calculated and sent by the N269 with data transmissions. The incoming checksum is not checked unless dip switch SW11-2 is in the down position. Thus it is recommended that switch SW11-2 is left down unless the interface is being tested.